



# ISP1760

## Hi-Speed USB host controller for embedded applications

Rev. 07 — 30 November 2009

Product data sheet

## 1. General description

---

The ISP1760 is a Hi-Speed Universal Serial Bus (USB) host controller with a generic processor interface. It integrates one Enhanced Host Controller Interface (EHCI), one Transaction Translator (TT) and three transceivers. The host controller portion of the ISP1760 and the three transceivers comply to [Ref. 1 “Universal Serial Bus Specification Rev. 2.0”](#). The EHCI portion of the ISP1760 is adapted from [Ref. 2 “Enhanced Host Controller Interface Specification for Universal Serial Bus Rev. 1.0”](#).

The integrated high-performance Hi-Speed USB transceivers enable the ISP1760 to handle all Hi-Speed USB transfer speed modes: high-speed (480 Mbit/s), full-speed (12 Mbit/s) and low-speed (1.5 Mbit/s). The three downstream ports allow simultaneous connection of three devices at different speeds (high-speed, full-speed and low-speed).

The generic processor interface allows the ISP1760 to be connected to various processors as a memory-mapped resource. The ISP1760 is a slave host: it does not require ‘bus-mastering’ capabilities of the host system bus. The interface can be configured, ensuring compatibility with a variety of processors. Data transfer can be performed on 16 bits or 32 bits, using Programmed Input/Output (PIO) or Direct Memory Access (DMA) with major control signals configurable as active LOW or active HIGH.

Integration of the TT allows connection to full-speed and low-speed devices, without the need of integrating Open Host Controller Interface (OHCI) or Universal Host Controller Interface (UHCI). Instead of dealing with two sets of software drivers, EHCI and OHCI or UHCI, you need to deal with only one set, EHCI, that dramatically reduces software complexity and IC cost.

## 2. Features

---

- The host controller portion of the ISP1760 complies with [Ref. 1 “Universal Serial Bus Specification Rev. 2.0”](#)
- The EHCI portion of the ISP1760 is adapted from [Ref. 2 “Enhanced Host Controller Interface Specification for Universal Serial Bus Rev. 1.0”](#)
- Contains three integrated Hi-Speed USB transceivers that support high-speed, full-speed and low-speed modes
- Integrates a TT for Original USB (full-speed and low-speed) device support
- Up to 64 kB internal memory (8 k × 64 bits) accessible through a generic processor interface; operation in multitasking environments is made possible by the implementation of virtual segmentation mechanism with bank switching on task request
- Generic processor interface, non-multiplexed and variable latency, with a configurable 32-bit or 16-bit external data bus; the processor interface can be defined as variable-latency or SRAM type (memory mapping)

- Slave DMA support to reduce the load of the host system CPU during the data transfer to or from the memory
- Integrated Phase-Locked Loop (PLL) with a 12 MHz crystal or an external clock input
- Integrated multi-configuration FIFO
- Optimized 'msec-based' or 'multi-msec-based' Proprietary Transfer Descriptor (PTD) interrupt
- Tolerant I/O for low voltage CPU interface (1.65 V to 3.6 V)
- 3.3 V-to-5.0 V external power supply input
- Integrated 5.0 V-to-1.8 V or 3.3 V-to-1.8 V voltage regulator (internal 1.8 V for low-power core)
- Internal power-on reset and low-voltage reset
- Supports suspend and remote wake-up
- Target current consumption:
  - ◆ Normal operation; one port in high-speed active:  $I_{CC} < 100 \text{ mA}$
  - ◆ Suspend mode:  $I_{CC(susp)} < 150 \text{ }\mu\text{A}$  at room temperature
- Built-in configurable overcurrent circuitry (digital or analog overcurrent protection)
- Available in LQFP128 and TFBGA128 packages

### 3. Applications

The ISP1760 can be used to implement a Hi-Speed USB compliant host controller connected to most of the CPUs present in the market today, having a generic processor interface with de-multiplexed address and data bus. This is because of the efficient slave-type interface of the ISP1760.

The internal architecture of the ISP1760 is such that it can be used in a large spectrum of applications requiring a high-performance internal host controller.

#### 3.1 Examples of a multitude of possible applications

- Set-top box: for connecting external high-performance mass storage devices
- Mobile phone: for connecting various USB devices
- Personal Digital Assistant (PDA): for connecting a large variety of USB devices
- Printer: for connecting external memory card readers, allowing direct printing
- Digital Still Camera (DSC): for printing to an external USB printer, for direct printing
- Mass storage: for connecting external memory card readers or other mass storage devices, for direct back-up

The low power consumption and deep power management modes of the ISP1760 make it particularly suitable for use in portable devices.

### 4. Ordering information

**Table 1. Ordering information**

Commercial product code	Package description	Packing	Minimum sellable quantity
ISP1760BEUM	LQFP128; 128 leads; body 14 × 20 × 1.4 (mm)	13-inch tape and reel dry pack	1000 pieces
ISP1760BEGA	LQFP128; 128 leads; body 14 × 20 × 1.4 (mm)	single tray dry pack	72 pieces
ISP1760ETUM	TFBGA128; 128 balls; body 9 × 9 × 0.8 (mm)	13-inch tape and reel dry pack	1000 pieces
ISP1760ETGA	TFBGA128; 128 balls; body 9 × 9 × 0.8 (mm)	single tray dry pack	260 pieces

## 5. Block diagram

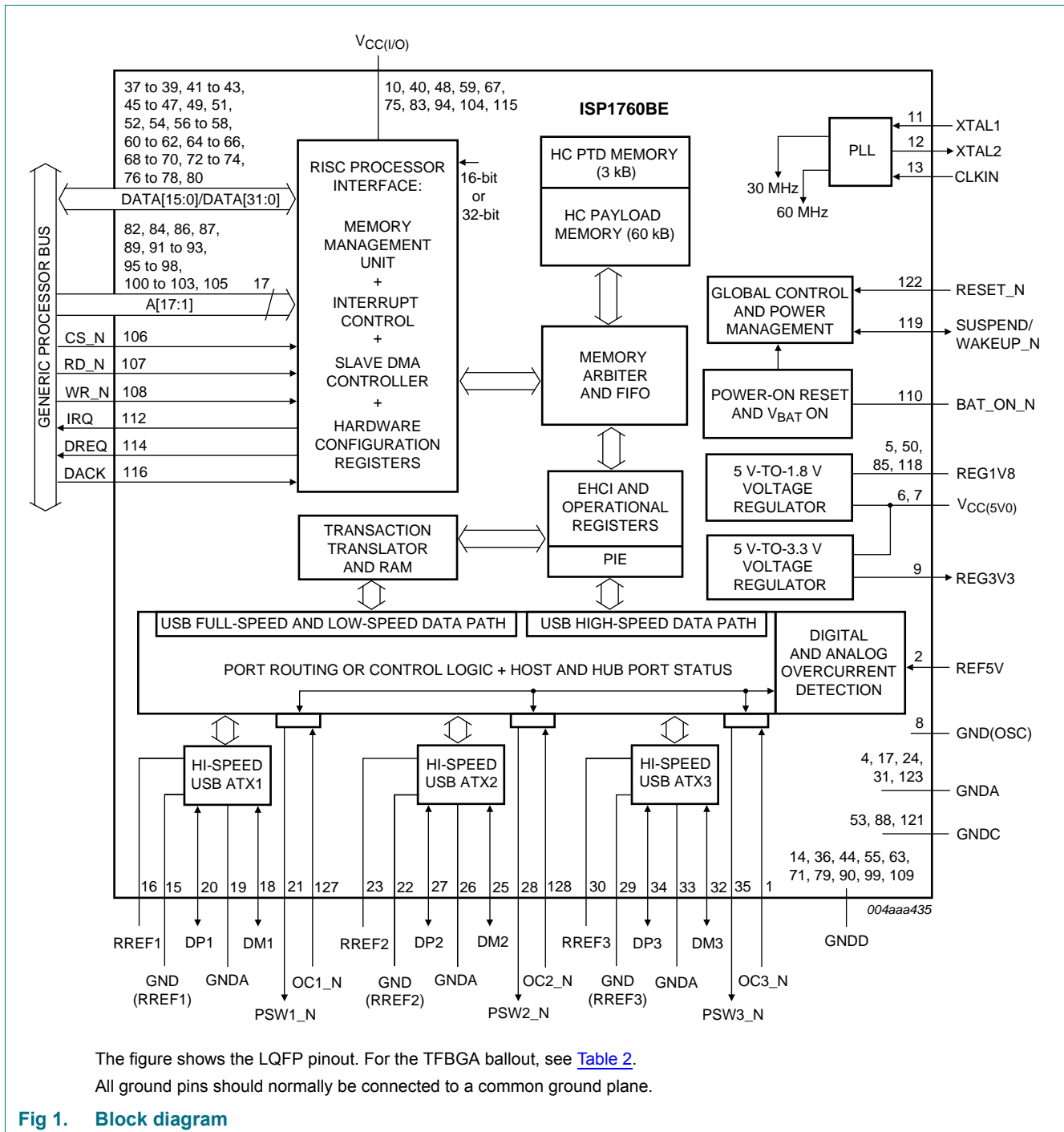

## 6. Pinning information

### 6.1 Pinning

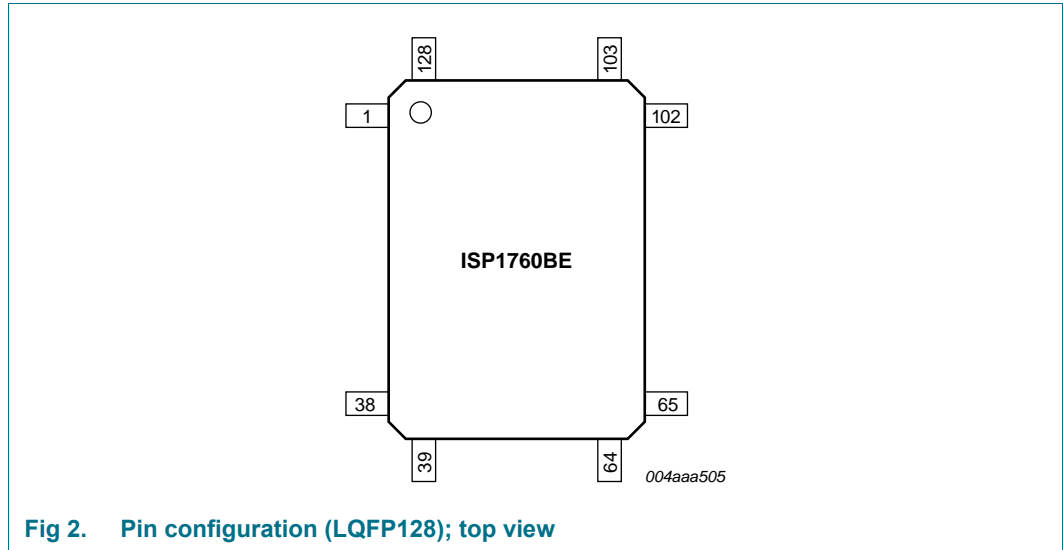

Fig 2. Pin configuration (LQFP128); top view

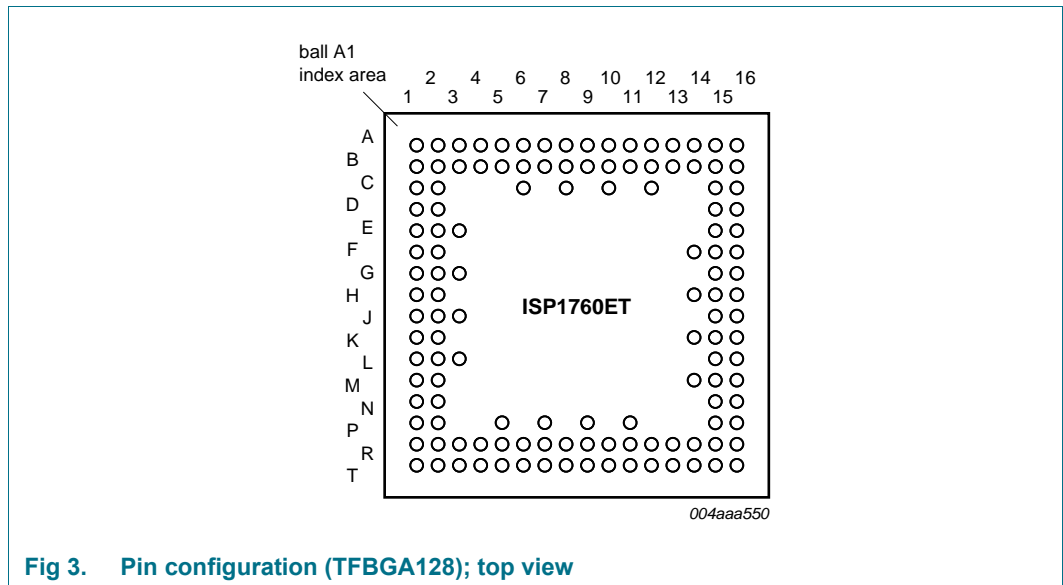

Fig 3. Pin configuration (TFBGA128); top view

### 6.2 Pin description

**Table 2. Pin description**

Symbol <sup>[1][2]</sup>	Pin		Type <sup>[3]</sup>	Description
	LQFP128	TFBGA128		
OC3_N	1	C2	AI	port 3 analog (5 V input) and digital overcurrent input; if not used, connect to $V_{CC(I/O)}$ through a 10 k $\Omega$ resistor input, 5 V tolerant
REF5V	2	A2	AI	5 V reference input for analog OC detector; connect a 100 nF decoupling capacitor
TEST1	3	B2	-	connect to ground
GNDA	4	A1	-	analog ground
REG1V8	5	B1	P	core power output (1.8 V); internal 1.8 V for the digital core; used for decoupling; connect a 100 nF capacitor; for details on additional capacitor placement, see <a href="#">Section 7.8</a>
$V_{CC(5V0)}$	6	C1	P	input to internal regulators (3.0 V to 5.5 V); connect a 100 nF decoupling capacitor; see <a href="#">Section 7.8</a>
$V_{CC(5V0)}$	7	D2	P	input to internal regulators (3.0 V to 5.5 V); connect a 100 nF decoupling capacitor; see <a href="#">Section 7.8</a>
GND(OSC)	8	E3	-	oscillator ground
REG3V3	9	D1	P	regulator output (3.3 V); for decoupling only; connect a 100 nF capacitor and a 4.7 $\mu$ F-to-10 $\mu$ F capacitor; see <a href="#">Section 7.8</a>
$V_{CC(I/O)}$	10	E2	P	digital supply voltage; 1.65 V to 3.6 V; connect a 100 nF decoupling capacitor; see <a href="#">Section 7.8</a>
XTAL1	11	E1	AI	12 MHz crystal connection input; connect to ground if an external clock is used; see <a href="#">Table 92</a>
XTAL2	12	F2	AO	12 MHz crystal connection output
CLKIN	13	F1	I	12 MHz oscillator or clock input; when not in use, connect to $V_{CC(I/O)}$
GNDD	14	G3	-	digital ground
GND(RREF1)	15	G2	-	RREF1 ground
RREF1	16	G1	AI	reference resistor connection; connect a 12 k $\Omega$ $\pm$ 1 % resistor between this pin and the RREF1 ground
GNDA <sup>[4]</sup>	17	H2	-	analog ground
DM1	18	H1	AI/O	downstream data minus port 1
GNDA	19	J3	-	analog ground
DP1	20	J2	AI/O	downstream data plus port 1
PSW1_N	21	J1	OD	power switch port 1, active LOW output pad, push-pull open-drain, 8 mA output drive, 5 V tolerant
GND(RREF2)	22	K2	-	RREF2 ground
RREF2	23	K1	AI	reference resistor connection; connect a 12 k $\Omega$ $\pm$ 1 % resistor between this pin and the RREF2 ground
GNDA <sup>[5]</sup>	24	L3	-	analog ground
DM2	25	L1	AI/O	downstream data minus port 2
GNDA	26	L2	-	analog ground
DP2	27	M2	AI/O	downstream data plus port 2

**Table 2. Pin description ...continued**

Symbol <sup>[1][2]</sup>	Pin		Type <sup>[3]</sup>	Description
	LQFP128	TFBGA128		
PSW2_N	28	M1	OD	power switch port 2, active LOW output pad, push-pull open-drain, 8 mA output drive, 5 V tolerant
GND(RREF3)	29	N2	-	RREF3 ground
RREF3	30	N1	AI	reference resistor connection; connect a 12 kΩ ± 1 % resistor between this pin and the RREF3 ground
GNDA <sup>[6]</sup>	31	P2	-	analog ground
DM3	32	P1	AI/O	downstream data minus port 3
GNDA	33	R2	-	analog ground
DP3	34	R1	AI/O	downstream data plus port 3
PSW3_N	35	T1	OD	power switch port 3, active LOW output pad, push-pull open-drain, 8 mA output drive, 5 V tolerant
GNDD	36	T2	-	digital ground
DATA0	37	R3	I/O	data bit 0 input and output bidirectional pad, push-pull input, 3-state output, 4 mA output drive, 3.3 V tolerant
DATA1	38	T3	I/O	data bit 1 input and output bidirectional pad, push-pull input, 3-state output, 4 mA output drive, 3.3 V tolerant
DATA2	39	R4	I/O	data bit 2 input and output bidirectional pad, push-pull input, 3-state output, 4 mA output drive, 3.3 V tolerant
V <sub>CC(I/O)</sub>	40	T4	P	digital supply voltage; 1.65 V to 3.6 V; connect a 100 nF decoupling capacitor; see <a href="#">Section 7.8</a>
DATA3	41	P5	I/O	data bit 3 input and output bidirectional pad, push-pull input, 3-state output, 4 mA output drive, 3.3 V tolerant
DATA4	42	T5	I/O	data bit 4 input and output bidirectional pad, push-pull input, 3-state output, 4 mA output drive, 3.3 V tolerant
DATA5	43	R5	I/O	data bit 5 input and output bidirectional pad, push-pull input, 3-state output, 4 mA output drive, 3.3 V tolerant
GNDD	44	T6	-	digital ground
DATA6	45	R6	I/O	data bit 6 input and output bidirectional pad, push-pull input, 3-state output, 4 mA output drive, 3.3 V tolerant
DATA7	46	P7	I/O	data bit 7 input and output bidirectional pad, push-pull input, 3-state output, 4 mA output drive, 3.3 V tolerant
DATA8	47	T7	I/O	data bit 8 input and output bidirectional pad, push-pull input, 3-state output, 4 mA output drive, 3.3 V tolerant
V <sub>CC(I/O)</sub>	48	R7	P	digital supply voltage; 1.65 V to 3.6 V; connect a 100 nF decoupling capacitor; see <a href="#">Section 7.8</a>

**Table 2. Pin description ...continued**

Symbol <sup>[1][2]</sup>	Pin		Type <sup>[3]</sup>	Description
	LQFP128	TFBGA128		
DATA9	49	T8	I/O	data bit 9 input and output bidirectional pad, push-pull input, 3-state output, 4 mA output drive, 3.3 V tolerant
REG1V8	50	R8	P	core power output (1.8 V); internal 1.8 V for the digital core; used for decoupling; connect a 100 nF capacitor; for details on additional capacitor placement, see <a href="#">Section 7.8</a>
DATA10	51	P9	I/O	data bit 10 input and output bidirectional pad, push-pull input, 3-state output, 4 mA output drive, 3.3 V tolerant
DATA11	52	T9	I/O	data bit 11 input and output bidirectional pad, push-pull input, 3-state output, 4 mA output drive, 3.3 V tolerant
GNDC	53	R9	-	core ground
DATA12	54	T10	I/O	data bit 12 input and output bidirectional pad, push-pull input, 3-state output, 4 mA output drive, 3.3 V tolerant
GNDD	55	R10	-	digital ground
DATA13	56	P11	I/O	data bit 13 input and output bidirectional pad, push-pull input, 3-state output, 4 mA output drive, 3.3 V tolerant
DATA14	57	T11	I/O	data bit 14 input and output bidirectional pad, push-pull input, 3-state output, 4 mA output drive, 3.3 V tolerant
DATA15	58	R11	I/O	data bit 15 input and output bidirectional pad, push-pull input, 3-state output, 4 mA output drive, 3.3 V tolerant
V <sub>CC(I/O)</sub>	59	T12	P	digital supply voltage; 1.65 V to 3.6 V; connect a 100 nF decoupling capacitor; see <a href="#">Section 7.8</a>
DATA16	60	R12	I/O	data bit 16 input and output bidirectional pad, push-pull input, 3-state output, 4 mA output drive, 3.3 V tolerant
DATA17	61	T13	I/O	data bit 17 input and output bidirectional pad, push-pull input, 3-state output, 4 mA output drive, 3.3 V tolerant
DATA18	62	R13	I/O	data bit 18 input and output bidirectional pad, push-pull input, 3-state output, 4 mA output drive, 3.3 V tolerant
GNDD	63	R14	-	digital ground
DATA19	64	T14	I/O	data bit 19 input and output bidirectional pad, push-pull input, 3-state output, 4 mA output drive, 3.3 V tolerant
DATA20	65	T15	I/O	data bit 20 input and output bidirectional pad, push-pull input, 3-state output, 4 mA output drive, 3.3 V tolerant



**Table 2. Pin description ...continued**

Symbol <sup>[1][2]</sup>	Pin		Type <sup>[3]</sup>	Description
	LQFP128	TFBGA128		
DATA21	66	R15	I/O	data bit 21 input and output bidirectional pad, push-pull input, 3-state output, 4 mA output drive, 3.3 V tolerant
V <sub>CC(I/O)</sub>	67	P15	P	digital supply voltage; 1.65 V to 3.6 V; connect a 100 nF decoupling capacitor; see <a href="#">Section 7.8</a>
DATA22	68	T16	I/O	data bit 22 input and output bidirectional pad, push-pull input, 3-state output, 4 mA output drive, 3.3 V tolerant
DATA23	69	R16	I/O	data bit 23 input and output bidirectional pad, push-pull input, 3-state output, 4 mA output drive, 3.3 V tolerant
DATA24	70	P16	I/O	data bit 24 input and output bidirectional pad, push-pull input, 3-state output, 4 mA output drive, 3.3 V tolerant
GNDD	71	N16	-	digital ground
DATA25	72	N15	I/O	data bit 25 input and output bidirectional pad, push-pull input, 3-state output, 4 mA output drive, 3.3 V tolerant
DATA26	73	M15	I/O	data bit 26 input and output bidirectional pad, push-pull input, 3-state output, 4 mA output drive, 3.3 V tolerant
DATA27	74	M16	I/O	data bit 27 input and output bidirectional pad, push-pull input, 3-state output, 4 mA output drive, 3.3 V tolerant
V <sub>CC(I/O)</sub>	75	M14	P	digital supply voltage; 1.65 V to 3.6 V; connect a 100 nF decoupling capacitor; see <a href="#">Section 7.8</a>
DATA28	76	L16	I/O	data bit 28 input and output bidirectional pad, push-pull input, 3-state output, 4 mA output drive, 3.3 V tolerant
DATA29	77	L15	I/O	data bit 29 input and output bidirectional pad, push-pull input, 3-state output, 4 mA output drive, 3.3 V tolerant
DATA30	78	K16	I/O	data bit 30 input and output bidirectional pad, push-pull input, 3-state output, 4 mA output drive, 3.3 V tolerant
GNDD	79	K15	-	digital ground
DATA31	80	K14	I/O	data bit 31 input and output bidirectional pad, push-pull input, 3-state output, 4 mA output drive, 3.3 V tolerant
TEST2	81	J16	-	connect to ground
A1	82	H16	I	address pin 1 input, 3.3 V tolerant
V <sub>CC(I/O)</sub>	83	J15	P	digital supply voltage; 1.65 V to 3.6 V; connect a 100 nF decoupling capacitor; see <a href="#">Section 7.8</a>

**Table 2. Pin description ...continued**

Symbol <sup>[1][2]</sup>	Pin		Type <sup>[3]</sup>	Description
	LQFP128	TFBGA128		
A2	84	H15	I	address pin 2 input, 3.3 V tolerant
REG1V8	85	G16	P	core power output (1.8 V); internal 1.8 V for the digital core; used for decoupling; connect a 100 nF capacitor and a 4.7 μF-to-10 μF capacitor; see <a href="#">Section 7.8</a>
A3	86	H14	I	address pin 3 input, 3.3 V tolerant
A4	87	F16	I	address pin 4 input, 3.3 V tolerant
GNDC	88	G15	-	core ground
A5	89	F15	I	address pin 5 input, 3.3 V tolerant
GNDD	90	E16	-	digital ground
A6	91	F14	I	address pin 6 input, 3.3 V tolerant
A7	92	E15	I	address pin 7 input, 3.3 V tolerant
A8	93	D16	I	address pin 8 input, 3.3 V tolerant
V <sub>CC(I/O)</sub>	94	D15	P	digital supply voltage; 1.65 V to 3.6 V; connect a 100 nF decoupling capacitor; see <a href="#">Section 7.8</a>
A9	95	C16	I	address pin 9 input, 3.3 V tolerant
A10	96	C15	I	address pin 10 input, 3.3 V tolerant
A11	97	B16	I	address pin 11 input, 3.3 V tolerant
A12	98	B15	I	address pin 12 input, 3.3 V tolerant
GNDD	99	A16	-	digital ground
A13	100	A15	I	address pin 13 input, 3.3 V tolerant
A14	101	B14	I	address pin 14 input, 3.3 V tolerant
A15	102	A14	I	address pin 15 input, 3.3 V tolerant
A16	103	A13	I	address pin 16 input, 3.3 V tolerant
V <sub>CC(I/O)</sub>	104	B13	P	digital supply voltage; 1.65 V to 3.6 V; connect a 100 nF decoupling capacitor; see <a href="#">Section 7.8</a>
A17	105	C12	I	address pin 17 input, 3.3 V tolerant

**Table 2. Pin description ...continued**

Symbol <sup>[1][2]</sup>	Pin		Type <sup>[3]</sup>	Description
	LQFP128	TFBGA128		
CS_N	106	A12	I	chip select signal assertion indicates the ISP1760 being accessed; active LOW input, 3.3 V tolerant
RD_N	107	B12	I	read enable; active LOW input, 3.3 V tolerant
WR_N	108	B11	I	write enable; active LOW input, 3.3 V tolerant
GNDD	109	A11	-	digital ground
BAT_ON_N	110	C10	OD	to indicate the presence of a minimum 3.3 V on pins 6 and 7 (open-drain); connect to $V_{CC(I/O)}$ through a 10 k $\Omega$ pull-up resistor output pad, push-pull open-drain, 8 mA output drive, 5 V tolerant
n.c.	111	A10	-	not connected
IRQ	112	B10	O	host controller interrupt signal output pad, 4 mA drive, 3.3 V tolerant
n.c.	113	A9	-	not connected
DREQ	114	B9	O	DMA controller request for the host controller output pad, 4 mA drive, 3.3 V tolerant
$V_{CC(I/O)}$	115	C8	P	digital supply voltage; 1.65 V to 3.6 V; connect a 100 nF decoupling capacitor; see <a href="#">Section 7.8</a>
DACK	116	A8	I	host controller DMA request acknowledgment; when not in use, connect to $V_{CC(I/O)}$ through a 10 k $\Omega$ pull-up resistor input, 3.3 V tolerant
TEST3	117	B8	-	connect to $V_{CC(I/O)}$ through a 10 k $\Omega$ pull-up resistor
REG1V8	118	B7	P	core power output (1.8 V); internal 1.8 V for the digital core; used for decoupling; connect a 100 nF capacitor; for details on additional capacitor placement, see <a href="#">Section 7.8</a>
SUSPEND/ WAKEUP_N	119	A7	I/OD	host controller suspend and wake-up; 3-state suspend output (active LOW) and wake-up input circuits are connected together <ul style="list-style-type: none"> <li>• HIGH = output is 3-state; ISP1760 is in suspend mode</li> <li>• LOW = output is LOW; ISP1760 is not in suspend mode</li> </ul> connect to $V_{CC(I/O)}$ through an external 10 k $\Omega$ pull-up resistor output pad, open-drain, 4 mA output drive, 3.3 V tolerant
TEST4	120	C6	-	pull up to $V_{CC(I/O)}$
GNDC	121	A6	-	core ground
RESET_N	122	B6	I	external power-up reset; active LOW; when reset is asserted, it is expected that bus signals are idle, that is, not toggling input, 3.3 V tolerant <b>Remark:</b> During reset, ensure that all the input pins to the ISP1760 are not toggling and are in their inactive states.
GNDA	123	B5	-	analog ground
TEST5	124	A5	-	connect a 220 nF capacitor between this pin and pin 125
TEST6	125	B4	-	connect a 220 nF capacitor between this pin and pin 124

**Table 2. Pin description ...continued**

Symbol <sup>[1][2]</sup>	Pin		Type <sup>[3]</sup>	Description
	LQFP128	TFBGA128		
TEST7	126	A4	-	connect to 3.3 V
OC1_N	127	B3	AI	port 1 analog (5 V input) and digital overcurrent input; if not used, connect to $V_{CC(I/O)}$ through a 10 k $\Omega$ resistor input, 5 V tolerant
OC2_N	128	A3	AI	port 2 analog (5 V input) and digital overcurrent input; if not used, connect to $V_{CC(I/O)}$ through a 10 k $\Omega$ resistor input, 5 V tolerant

[1] Symbol names ending with underscore N, for example, NAME\_N, represent active LOW signals.

[2] All ground pins should normally be connected to a common ground plane.

[3] I = input only; O = output only; I/O = digital input/output; OD = open-drain output; AI/O = analog input/output; AI = analog input; P = power.

[4] For port 1.

[5] For port 2.

[6] For port 3.

## 7. Functional description

---

### 7.1 ISP1760 internal architecture: advanced ST-Ericsson slave host controller and hub

The EHCI block and the Hi-Speed USB hub block are the main components of the advanced ST-Ericsson slave host controller.

The EHCI is the latest generation design, with improved data bandwidth. The EHCI in the ISP1760 is adapted from [Ref. 2 “Enhanced Host Controller Interface Specification for Universal Serial Bus Rev. 1.0”](#).

The internal Hi-Speed USB hub block replaces the companion host controller block used in the original PCI Hi-Speed USB host controllers to handle full-speed and low-speed modes. The hardware architecture in the ISP1760 is simplified to help reduce cost and development time, by eliminating the additional work involved in implementing the OHCI software required to support full-speed and low-speed modes.

[Figure 4](#) shows the internal architecture of the ISP1760. The ISP1760 implements the EHCI that has an internal port, the root hub port (not available externally), on which the internal hub is connected. The three external ports are always routed to the internal hub. The internal hub is a Hi-Speed USB (USB 2.0) hub, including the TT.

**Remark:** The root hub must be enabled and the internal hub must be enumerated. Enumerate the internal hub as if it is externally connected. For details, refer to [Ref. 5 “Interfacing the ISP176x to the Intel PXA25x processor \(AN10037\)”](#).

At the host controller reset and initialization, the internal root hub port will be polled until a new connection is detected, showing the connection of the internal hub.

The internal Hi-Speed USB hub is enumerated using a sequence similar to a standard Hi-Speed USB hub enumeration sequence, and the polling on the root hub is stopped because the internal Hi-Speed USB hub will never be disconnected. When enumerated, the internal hub will report the three externally available ports.

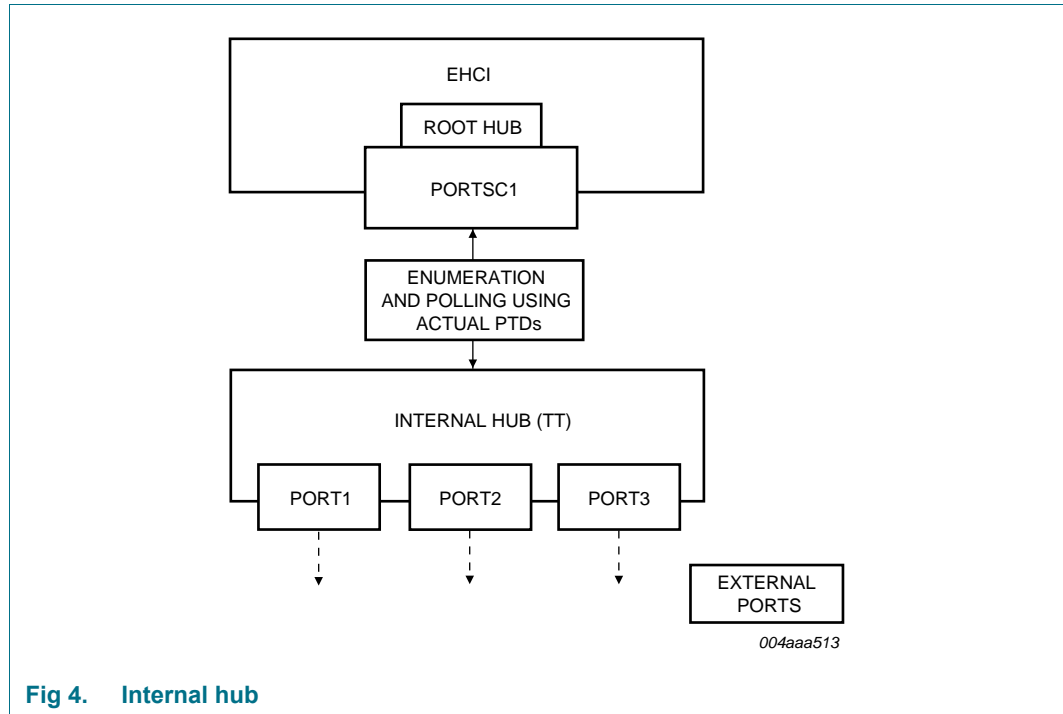

### 7.1.1 Internal clock scheme and port selection

The ISP1760 has three ports. [Figure 5](#) shows the internal clock scheme of the ISP1760.

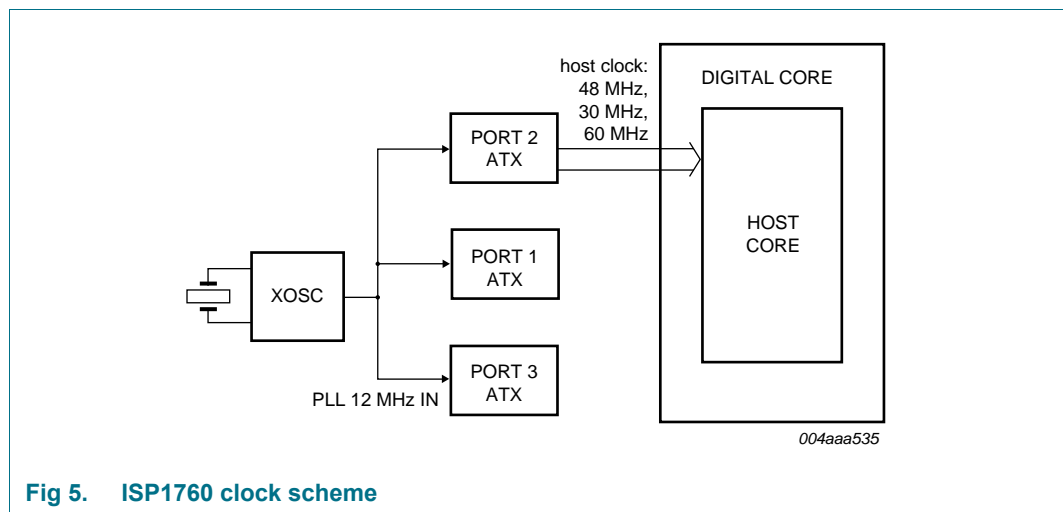

[Figure 5](#) shows that the host clock is derived from port 2. Port 2 does not need to be enabled by software, if only port 1 or port 3 is used. No port needs to be disabled by external pull-up resistors, if not used. The DP and DM of the unused ports need not be externally pulled HIGH because there are internal pull-down resistors on each port that are enabled by default.

[Table 3](#) lists the various port connection scenarios.

**Table 3. Port connection scenarios**

Port configuration	Port 1	Port 2	Port 3
One port (port 1)	DP and DM are routed to USB connector	DP and DM are not connected (left open)	DP and DM are not connected (left open)
One port (port 2)	DP and DM are not connected (left open)	DP and DM are routed to USB connector	DP and DM are not connected (left open)
One port (port 3)	DP and DM are not connected (left open)	DP and DM are not connected (left open)	DP and DM are routed to USB connector
Two ports (ports 1 and 2)	DP and DM are routed to USB connector	DP and DM are routed to USB connector	DP and DM are not connected (left open)
Two ports (ports 2 and 3)	DP and DM are not connected (left open)	DP and DM are routed to USB connector	DP and DM are routed to USB connector
Two ports (ports 1 and 3)	DP and DM are routed to USB connector	DP and DM are not connected (left open)	DP and DM are routed to USB connector
Three ports (ports 1, 2 and 3)	DP and DM are routed to USB connector	DP and DM are routed to USB connector	DP and DM are routed to USB connector

## 7.2 Host controller buffer memory block

### 7.2.1 General considerations

The internal addressable host controller buffer memory is 63 kB. The 63 kB effective memory size is the result of subtracting the size of the registers (1 kB) from the total addressable memory space defined in the ISP1760 (64 kB). This is the optimized value to achieve the highest performance with minimal cost.

The ISP1760 is a slave host controller. This means that it does not need access to the local bus of the system to transfer data from the system memory to the ISP1760 internal memory, unlike the case of the original PCI Hi-Speed USB host controllers. Therefore, correct data must be transferred to both the PTD area and the payload area by PIO (using CPU access) or programmed DMA.

The 'slave-host' architecture ensures better compatibility with most of the processors present in the market today because not all processors allow a 'bus-master' on the local bus. It also allows better load balancing of the processor's local bus because only the internal bus arbiter of the processor controls the transfer of data dedicated to USB. This prevents the local bus from being busy when other more important transfers may be in the queue; and therefore achieving a 'linear' system data flow that has less impact on other processes running at the same time.

The considerations mentioned are also the main reason for implementing the pre-fetching technique, instead of using a READY signal. The resulting architecture avoids 'freezing' of the local bus, by asserting READY, enhancing the ISP1760 memory access time, and avoiding introduction of programmed additional wait states. For details, see [Section 7.3](#) and [Section 8.3.8](#).

The total amount of memory allocated to the payload determines the maximum transfer size specified by a PTD, a larger internal memory size results in less CPU interruption for transfer programming. This means less time spent in context switching, resulting in better CPU usage.

A larger buffer also implies a larger amount of data can be transferred. The transfer, however, can be done over a longer period of time, to maintain the overall system performance. Each transfer of the USB data on the USB bus can span for up to a few milliseconds before requiring further CPU intervention for data movement.

The internal architecture of the ISP1760 allows a flexible definition of the memory buffer for optimization of the data transfer on the CPU extension bus and the USB. It is possible to implement various data transfer schemes, depending on the number and type of USB devices present. For example: push-pull; data can be written to half of the memory while data in the other half is being accessed by the host controller and sent on the USB bus. This is useful especially when a high-bandwidth 'continuous or periodic' data flow is required.

Through an analysis of the hardware and software environment regarding the usual data flow and performance requirements of most embedded systems, ST-Ericsson has determined the optimal size for the internal buffer as approximately 64 kB.

### 7.2.2 Structure of the ISP1760 host controller memory

The 63 kB internal memory consists of the PTD area and the payload area.

PTD memory zone is divided into three dedicated areas for each main type of USB transfer: Isochronous (ISO), Interrupt (INT) and Asynchronous Transfer List (ATL). As shown in [Table 4](#), the PTD areas for ISO, INT and ATL are grouped at the beginning of the memory, occupying the address range 0400h to 0FFFh, following the register address space. The payload or data area occupies the next memory address range 1000h to FFFFh, meaning that 60 kB of memory are allocated for the payload data.

A maximum of 32 PTD areas and their allocated payload areas can be defined for each type of transfer. The structure of a PTD is similar for every transfer type and consists of eight Double Words (DWs) that must be correctly programmed for a correct USB data transfer. The reserved bits of a PTD must be set to logic 0. A detailed description of the PTD structure can be found in [Section 9](#).

The transfer size specified by the PTD determines the contiguous USB data transfer that can be performed without any CPU intervention. The respective payload memory area must be equal to the transfer size defined. The maximum transfer size is flexible and can be optimized, depending on the number and nature of USB devices or PTDs defined and their respective MaxPacketSize.

The CPU will program the DMA to transfer the necessary data in the payload memory. The next CPU intervention will be required only when the current transfer is completed and DMA programming is necessary to transfer the next data payload. This is normally signaled by the IRQ that is generated by the ISP1760 on completing the current PTD, meaning all the data in the payload area was sent on the USB bus. The external IRQ signal is asserted according to the settings in the IRQ Mask OR or IRQ Mask AND registers, see [Section 8.4](#).

The RAM is structured in blocks of PTDs and payloads so that while the USB is executing on an active transfer-based PTD, the processor can simultaneously fill up another block area in the RAM. A PTD and its payload can then be updated on-the-fly without stopping or delaying any other USB transaction or corrupting the RAM data.

Some of the design features are:



- The address range of the internal RAM buffer is from 0400h to FFFFh.
- The internal memory contains isochronous, interrupt and asynchronous PTDs, and respective defined payloads.
- All accesses to the internal memory are double word aligned.
- Internal memory address range calculation:  
 $\text{Memory address} = (\text{CPU address} - 0400\text{h}) (\text{shift right } \gg 3)$ . Base address is 0400h.

**Table 4. Memory address**

Memory map	CPU address	Memory address
ISO	0400h to 07FFh	0000h to 007Fh
INT	0800h to 0BFFh	0080h to 00FFh
ATL	0C00h to 0FFFh	0100h to 017Fh
Payload	1000h to FFFFh	0180h to 1FFFh

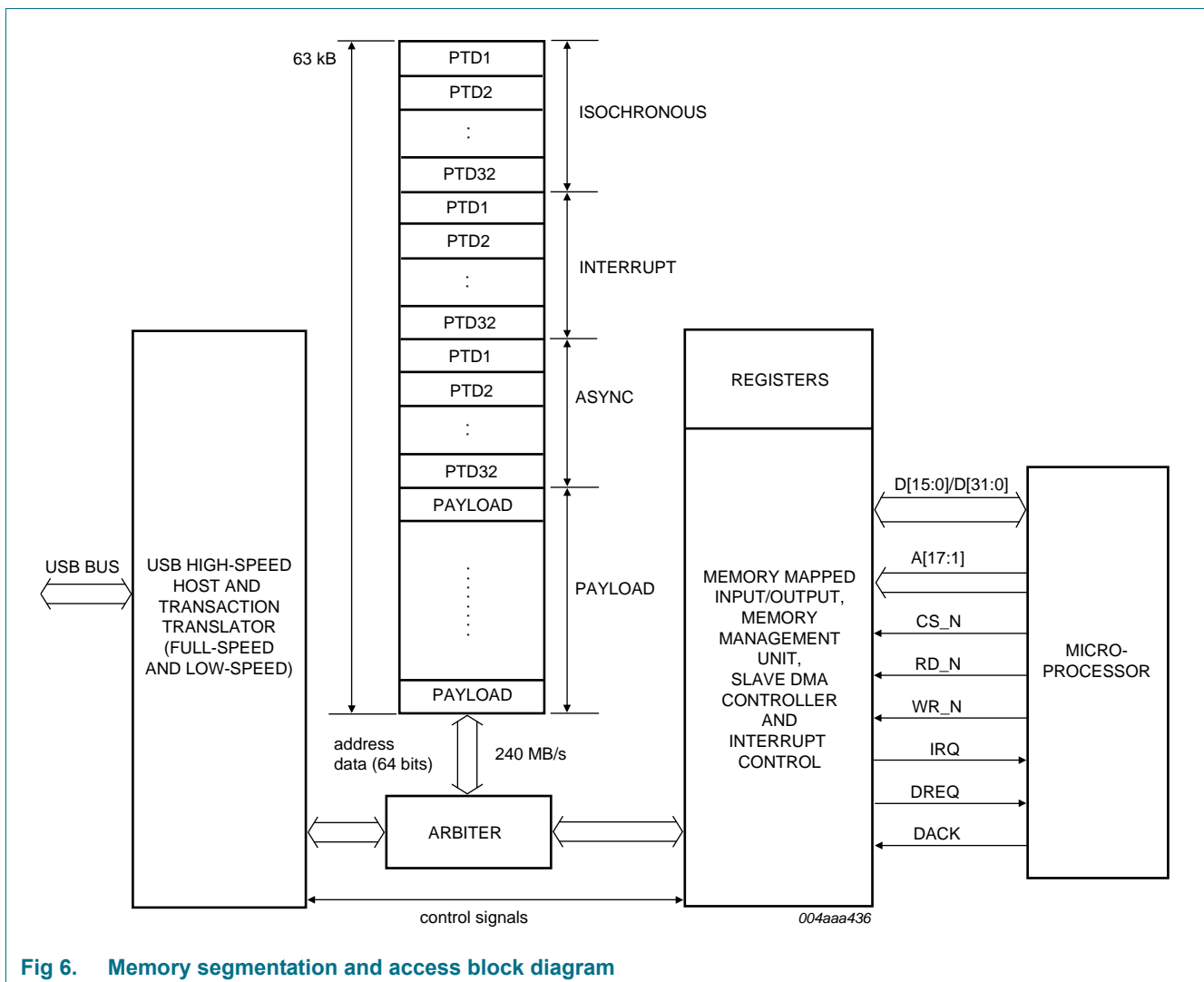

**Fig 6. Memory segmentation and access block diagram**

Both the CPU interface logic and the USB host controller require access to the internal ISP1760 RAM at the same time. The internal arbiter controls these accesses to the internal memory, organized internally on a 64-bit data bus width, allowing a maximum bandwidth of 240 MB/s. This bandwidth avoids any bottleneck on accesses both from the CPU interface and the internal USB host controller.

### 7.3 Accessing the ISP1760 host controller memory: PIO and DMA

The CPU interface of the ISP1760 can be configured for a 16-bit or 32-bit data bus width.

When the ISP1760 is configured for a 16-bit data bus width, the upper unused 16 data lines must be pulled up to  $V_{CC(I/O)}$ . This can be achieved by connecting DATA[31:16] lines together to a single 10 k $\Omega$  pull-up resistor. The 16-bit or 32-bit data bus width configuration is done by programming bit 8 of the HW Mode Control register. This will determine the register and memory access types in both PIO and DMA modes. All accesses must be word-aligned for 16-bit mode and double word aligned for 32-bit mode, where one word = 16 bits. When accessing the host controller registers in 16-bit mode, the register access must always be completed using two subsequent accesses. In the case of a DMA transfer, the 16-bit or 32-bit data bus width configuration will determine the number of bursts that will complete a certain transfer length.

In PIO mode, CS\_N, WR\_N and RD\_N are used to access registers and memory. In DMA mode, the data validation is performed by DACK, instead of CS\_N, together with the WR\_N and RD\_N signals. The DREQ signal will always be asserted as soon as the ISP1760 DMA is enabled.

#### 7.3.1 PIO mode access, memory read cycle

The following method has been implemented to reduce the read access timing in the case of a memory read:

- The Memory register contains the starting address and the bank selection to read from the memory. Before every new read cycle of the same or different banks, an appropriate value is written to this register.
- Once a value is written to this register, the address is stored in the FIFO of that bank and is then used to pre-fetch data for the memory read of that bank.

For every subsequent read operation executed at a contiguous address, the address pointer corresponding to that bank is automatically incremented to pre-fetch the next data to be sent to the CPU.

Memory read accesses for multiple banks can be interleaved. The FIFO block handles the multiplexing of appropriate data to the CPU.

- The address written to the Memory register is incremented and used to successively pre-fetch data from the memory irrespective of the value on the address bus for each bank, until a new value for a bank is written to the Memory register. This is valid only when the address refers to the memory space (400h to FFFFh).

For example, consider the following sequence of operations:

- Write the starting (read) address 4000h and bank1 = 01 to the Memory register. When RD\_N is asserted for three cycles with A[17:16] = 01, the returned data corresponds to addresses 4000h, 4004h and 4008h.

**Remark:** Once 4000h is written to the Memory register for bank1, the bank select value determines the successive incremental addresses used to fetch data. That is, the fetching of data is independent of the address on A[15:0] lines.

- Write the starting (read) address 4100h and bank2 = 10 to the Memory register. When RD\_N is asserted for four cycles with A[17:16] = 10, the returned data corresponds to addresses 4100h, 4104h, 4108h and 410Ch.

Consequently, the RD\_N assertion with A[17:16] = 01 will return data from 400Ch because the bank1 read stopped there in the previous cycle. Also, RD\_N assertions with A[17:16] = 10 will now return data from 4110h because the bank2 read stopped there in the previous cycle.

### 7.3.2 PIO mode access, memory write cycle

The PIO memory write access is similar to a normal memory access. It is not necessary to set the pre-fetching address before a write cycle to the memory.

The ISP1760 internal write address will not be automatically incremented during consecutive write accesses, unlike in a series of ISP1760 memory read cycles. The memory write address must be incremented before every access.

### 7.3.3 PIO mode access, register read cycle

The PIO register read access is similar to a general register access. It is not necessary to set a pre-fetching address before a register read.

The ISP1760 register read address will not be automatically incremented during consecutive read accesses, unlike in a series of ISP1760 memory read cycles. The ISP1760 register read address must be correctly specified before every access.

### 7.3.4 PIO mode access, register write cycle

The PIO register write access is similar to a general register access. It is not necessary to set a pre-fetching address before a register write.

The ISP1760 register write address will not be automatically incremented during consecutive write accesses, unlike in a series of ISP1760 memory read cycles. The ISP1760 register write address must be correctly specified before every access.

### 7.3.5 DMA mode, read and write operations

The internal ISP1760 host controller DMA is a slave DMA. The host system processor or DMA must ensure the data transfer to or from the ISP1760 memory.

The ISP1760 DMA supports a DMA burst length of 1, 4, 8 and 16 cycles for both the 16-bit and 32-bit data bus width. DREQ will be asserted at the beginning of the first burst of a DMA transfer and will be de-asserted on the last cycle, RD\_N or WR\_N active pulse, of that burst. It will be reasserted shortly after the DACK de-assertion, as long as the DMA transfer counter was not reached. DREQ will be de-asserted on the last cycle when the DMA transfer counter is reached and will not be reasserted until the DMA reprogramming is performed. Both the DREQ and DACK signals are programmable as active LOW or active HIGH, according to the system requirements.

The DMA start address must be initialized in the respective register, and the subsequent transfers will automatically increment the internal ISP1760 memory address. A register or memory access or access to other system memory can occur in between DMA bursts, whenever the bus is released because DACK is de-asserted, without affecting the DMA transfer counter or the current address.

Any memory area can be accessed by the system's DMA at any starting address because there are no predefined memory blocks. The DMA transfer must start on a word or double word address, depending on whether the data bus width is set to 16 bit or 32 bit. DMA is the most efficient method to initialize the payload area, to reduce the CPU usage and overall system loading.

The ISP1760 does not implement EOT to signal the end of a DMA transfer. If programmed, an interrupt may be generated by the ISP1760 at the end of the DMA transfer.

The slave DMA of the ISP1760 will issue a DREQ to the DMA controller of the system to indicate that it is programmed for transfer and data is ready. The system DMA controller may also start a transfer without the need of the DREQ, if the ISP1760 memory is available for the data transfer and the ISP1760 DMA programming is completed.

It is also possible that the system's DMA will perform a memory-to-memory type of transfer between the system memory and the ISP1760 memory. The ISP1760 will be accessed in PIO mode. Consequently, memory read operations must be preceded by initializing the Memory register (address 033Ch), as described in [Section 7.3.1](#). No IRQ will be generated by the ISP1760 on completing the DMA transfer but an internal processor interrupt may be generated to signal that the DMA transfer is completed. This is mainly useful in implementing the double-buffering scheme for data transfer to optimize the USB bandwidth.

The ISP1760 DMA programming involves:

- Set the active levels of signals DREQ and DACK in the HW Mode Control register.
- The DMA Start Address register contains the first memory address at which the data transfer will start. It must be word-aligned in 16-bit data bus mode and double word aligned in 32-bit data bus mode.
- The programming of the DMA Configuration register specifies:
  - The type of transfer that will be performed: read or write.
  - The burst size, expressed in bytes, is specified, regardless of the data bus width. For the same burst size, a double number of cycles will be generated in 16-bit mode data bus width as compared to 32-bit mode.
  - The transfer length, expressed in number of bytes, defines the number of bursts. The DREQ will be de-asserted and asserted to generate the next burst, as long as there are bytes to be transferred. At the end of a transfer, the DREQ will be de-asserted and an IRQ can be generated if DMAEOTINT (bit 3 in the Interrupt register) is set. The maximum DMA transfer size is equal to the maximum memory size. The transfer size can be an odd or even number of bytes, as required. If the transfer size is an odd number of bytes, the number of bytes transferred by the system's DMA is equal to the next multiple of two for the 16-bit data bus width or four for the 32-bit data bus width. For a write operation, however, only the specified odd number of bytes in the ISP1760 memory will be affected.

- Enable ENABLE\_DMA (bit 1) of the DMA Configuration register to determine the assertion of DREQ immediately after setting the bit.

After programming the preceding parameters, the system's DMA may be enabled, waiting for the DREQ to start the transfer or immediate transfer may be started.

The programming of the system's DMA must match the programming of the ISP1760 DMA parameters. Only one DMA transfer may take place at a time. PIO mode data transfer may occur simultaneously with a DMA data transfer, in the same or a different memory area.

## 7.4 Interrupts

The ISP1760 will assert an IRQ according to the source or event in the Interrupt register. The main steps to enable the IRQ assertion are:

1. Set GLOBAL\_INTR\_EN (bit 0) in the HW Mode Control register.
2. Define the IRQ active as level or edge in INTR\_LEVEL (bit 1) of the HW Mode Control register.
3. Define the IRQ polarity as active LOW or active HIGH in INTR\_POL (bit 2) of the HW Mode Control register. These settings must match the IRQ settings of the host processor.

By default, interrupt is level-triggered and active LOW.

4. Program the individual interrupt enable bits in the Interrupt Enable register. The software will need to clear the interrupt status bits in the Interrupt register before enabling individual interrupt enable bits.

Additional IRQ characteristics can be adjusted in the Edge Interrupt Count register, as necessary, applicable only when IRQ is set to be edge-active; a pulse of a defined width is generated every time IRQ is active.

Bits 15 to 0 of the Edge Interrupt Count register define the IRQ pulse width. The maximum pulse width that can be programmed is FFFFh, corresponding to a 1 ms pulse width. This setting is necessary for certain processors that may require a different minimum IRQ pulse width from the default value. The default IRQ pulse width set at power-on is approximately 500 ns.

Bits 31 to 24 of the Edge Interrupt Count register define the minimum interval between two interrupts to avoid frequent interrupts to the CPU. The default value of 00h attributed to these bits determines the normal IRQ generation, without any delay. When a delay is programmed and the IRQ becomes active after the respective delay, several IRQ events may have already occurred.

All the interrupt events are represented by the respective bits allocated in the Interrupt register. There is no mechanism to show the order or the moment of occurrence of an interrupt.

The asserted bits in the Interrupt register can be cleared by writing back the same value to the Interrupt register. This means that writing logic 1 to each of the set bits will reset the corresponding bits to the initial inactive state.

The IRQ generation rules that apply according to the preceding settings are:

- If an event of interrupt occurs but the respective bit in the Interrupt Enable register is not set, then the respective Interrupt register bit is set but the interrupt signal is not asserted.

An interrupt will be generated when interrupt is enabled and the respective bit in the Interrupt Enable register is set.

- For a level trigger, an interrupt signal remains asserted until the processor clears the Interrupt register by writing logic 1 to clear the Interrupt register bits that are set.
- If an interrupt is made edge-sensitive and is asserted, writing to clear the Interrupt register will not have any effect because the interrupt will be asserted for a prescribed amount of clock cycles.
- The clock stopping mechanism does not affect the generation of an interrupt. This is useful during the suspend and resume cycles, when an interrupt is generated to signal a wake-up event.

The IRQ generation can also be conditioned by programming the IRQ Mask OR and IRQ Mask AND registers.

With the help of the IRQ Mask AND and IRQ Mask OR registers for each type of transfer (ISO, INT and bulk), software can determine which PTDs get priority and an interrupt will be generated when the AND or OR conditions are met. The PTDs that are set will wait until the respective bits of the remaining PTDs are set and then all PTDs generate an interrupt request to the CPU together.

The registers definition shows that the AND or OR conditions are applicable to the same category of PTDs: ISO, INT, ATL.

When an IRQ is generated, the PTD Done Map registers and the respective V bits will show which PTDs were completed.

The rules that apply to the IRQ Mask AND or IRQ Mask OR settings are:

- The OR mask has a higher priority over the AND mask. An IRQ is generated if bit n of the done map is set and the corresponding bit n of the OR Mask register is set.
- If the OR mask for any done bit is not set, then the AND mask comes into picture. An IRQ is generated if all the corresponding done bits of the AND Mask register are set. For example: If bits 2, 4 and 10 are set in the AND Mask register, an IRQ is generated only if bits 2, 4, 10 of the done map are set.
- If using the IRQ interval setting for the bulk PTD, an interrupt will only occur at the regular time interval as programmed in the ATL Done Timeout register. Even if an interrupt event occurs before the time-out of the register, no IRQ will be generated until the time is up.

For an example on using the IRQ Mask AND or IRQ Mask OR registers without the ATL Done Timeout register, see [Table 5](#).

The AND function: Activate the IRQ only if PTDs 1, 2 and 4 are done.

The OR function: If any of the PTDs 7, 8 or 9 are done, an IRQ for each of the PTD will be raised.

**Table 5. Using the IRQ Mask AND or IRQ Mask OR registers**

PTD	AND register	OR register	Time	PTD done	IRQ
1	1	0	1 ms	1	-
2	1	0	-	1	-
3	0	0	-	-	-
4	1	0	3 ms	1	active because of AND
5	0	0	-	-	-
6	0	0	-	-	-
7	0	1	5 ms	1	active because of OR
8	0	1	6 ms	1	active because of OR
9	0	1	7 ms	1	active because of OR

## 7.5 Phase-Locked Loop (PLL) clock multiplier

The internal PLL requires a 12 MHz input, which can be a 12 MHz crystal or a 12 MHz clock already existing in the system with a precision better than 50 ppm. This allows the use of a low-cost 12 MHz crystal that also minimizes ElectroMagnetic Interference (EMI). When an external crystal is used, make sure the CLKIN pin is connected to  $V_{CC(I/O)}$ .

The PLL block generates all the main internal clocks required for normal functionality of various blocks: 30 MHz, 48 MHz and 60 MHz.

No external components are required for the PLL operation.

## 7.6 Power management

The ISP1760 implements a flexible power management scheme, allowing various power saving stages.

The usual powering scheme implies programming EHCI registers and the internal Hi-Speed USB (USB 2.0) hub in the same way it is done in the case of a PCI Hi-Speed USB host controller with a Hi-Speed USB hub attached.

When the ISP1760 is in suspend mode, the main internal clocks will be stopped to ensure minimum power consumption. An internal LazyClock of 100 kHz  $\pm$  40 % will continue running. This allows initiating a resume on one of these events:

- External USB device connect or disconnect
- CS\_N signal asserted when the ISP1760 is accessed
- Driving the SUSPEND/WAKEUP\_N pin to a LOW level

The SUSPEND/WAKEUP\_N pin is a bidirectional pin. This pin must be connected to one of the GPIO pins of a processor.

The awake state can be verified by reading the LOW level of this pin. If the level is HIGH, it means that the ISP1760 is in the suspend state.

The SUSPEND/WAKEUP\_N pin requires a pull-up because in the ISP1760 suspended state the pin becomes 3-state and can be pulled down, driving it externally by switching the processor's GPIO line to output mode to generate the ISP1760 wake-up.

The SUSPEND/WAKEUP\_N pin is a 3-state output. It is also an input to the internal wake-up logic.

When in suspend mode, the ISP1760 internal wake-up circuitry will sense the status of the SUSPEND/WAKEUP\_N pin:

- If it remains pulled-up, no wake-up is generated because a HIGH is sensed by the internal wake-up circuit.
- If the pin is externally pulled LOW, for example, by the GPIO line or just as a test by jumper, the input to the wake-up circuitry becomes LOW and the wake-up is internally initiated.

The resume state has a clock-off count timer defined by bits 31 to 16 of the Power Down Control register. The default value of this timer is 10 ms, meaning that the resume state will be maintained for 10 ms. If during this time, the RUN/STOP bit in the USBCMD register is set to logic 1, the host controller will go into a permanent resume; the normal functional state. If the RUN/STOP bit is not set during the time determined by the clock-off count, the ISP1760 will switch back to suspend mode after the specified time. The maximum delay that can be programmed in the clock-off count field is approximately 500 ms.

Additionally, the Power Down Control register allows the ISP1760 internal blocks to be disabled for lower power consumption as defined in [Table 55](#).

The lowest suspend current,  $I_{CC(susp)}$ , that can be achieved is approximately 150  $\mu$ A at room temperature. The suspend current will increase with the increase in temperature, with approximately 300  $\mu$ A at 40 °C and up to a typical 1 mA at 85 °C. The system is not in suspend mode when its temperature increases above 40 °C. Therefore, even a 1 mA current consumption by the ISP1760 in suspend mode can be considered negligible. In normal environmental conditions, when the system is in suspend mode, the maximum ISP1760 temperature will be approximately 40 °C determined by the ambient temperature so the ISP1760 maximum suspend current will be below 300  $\mu$ A. An alternative solution to achieve a very low suspend current is to completely switch off the  $V_{CC(5V0)}$  power input by using an external PMOS transistor, controlled by one of the GPIO pins of the processor. This is possible because the ISP1760 can be used in hybrid mode, which allows only the  $V_{CC(I/O)}$  powered on to avoid loading of the system bus.

When the ISP1760 power is always on, the time from wake-up to suspend will be approximately 100 ms.

It is necessary to wait for the CLKREADY interrupt assertion before programming the ISP1760 because internal clocks are stopped during deep-sleep suspend and restarted after the first wake-up event. The occurrence of the CLKREADY interrupt means that internal clocks are running and the normal functionality is achieved.

It is estimated that the CLKREADY interrupt will be generated less than 100  $\mu$ s after the wake-up event, if the power to the ISP1760 was on during suspend.

If the ISP1760 is used in hybrid mode and  $V_{CC(5V0)}$  is off during suspend, a 2 ms reset pulse is required when the power is switched back on, before the resume programming sequence starts. This will ensure that internal clocks are running and all logics reach a stable initial state.



### 7.7 Overcurrent detection

The ISP1760 can implement a digital or analog overcurrent detection scheme. Bit 15 of the HW Mode Control register can be programmed to select the analog or digital overcurrent detection. An analog overcurrent detection circuit is integrated on-chip. The main features of this circuit are self reporting, automatic resetting, low-trip time and low cost. This circuit offers an easy solution at no extra hardware cost on the board. The port power will automatically be disabled by the ISP1760 on an overcurrent event occurrence, by de-asserting the PSWn\_N signal without any software intervention.

When using the integrated analog overcurrent detection, the range of the overcurrent detection voltage for the ISP1760 is 45 mV to 100 mV. Calculation of external components should be based on the 45 mV value, with the actual overcurrent detection threshold usually positioned in the middle of the interval.

For an overcurrent limit of 500 mA per port, a PMOS with  $R_{DSon}$  of approximately 100 m $\Omega$  is required. If a PMOS with a lower  $R_{DSon}$  is used, analog overcurrent detection can be adjusted using a series resistor; see [Figure 7](#).

$\Delta V_{PMOS} = \Delta V_{trip(OC)} = \Delta V_{trip(int)} - (I_{OC(nom)} \times R_{adj(oc)})$ , where:

$\Delta V_{PMOS}$  = voltage drop on PMOS

$I_{OC(nom)} = 1 \mu A$

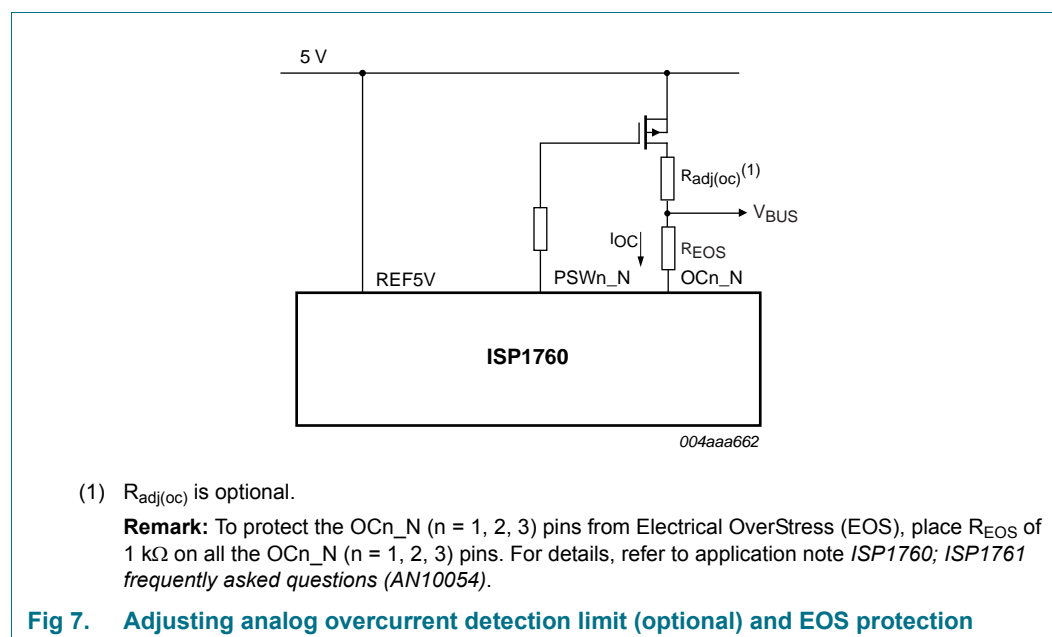

The digital overcurrent scheme requires using an external power switch with integrated overcurrent detection, such as LM3526, MIC2526 (2 ports) or LM3544 (4 ports). These devices are controlled by PSWn\_N signals corresponding to each port. In the case of overcurrent occurrence, these devices will assert OCn\_N signals. On OCn\_N assertion, the ISP1760 cuts off the port power by de-asserting PSWn\_N. The external integrated power switch will also automatically cut off the port power in the case of an overcurrent event, by implementing thermal shutdown. An internal delay filter will prevent false

overcurrent reporting because of in-rush currents when plugging a USB device. Because of this internal delay, as soon as OCn\_N is asserted, PSWn\_N will switch off the external PMOS in less than 15 ms.

### 7.8 Power supply

[Figure 8](#) shows the ISP1760 power supply connection.

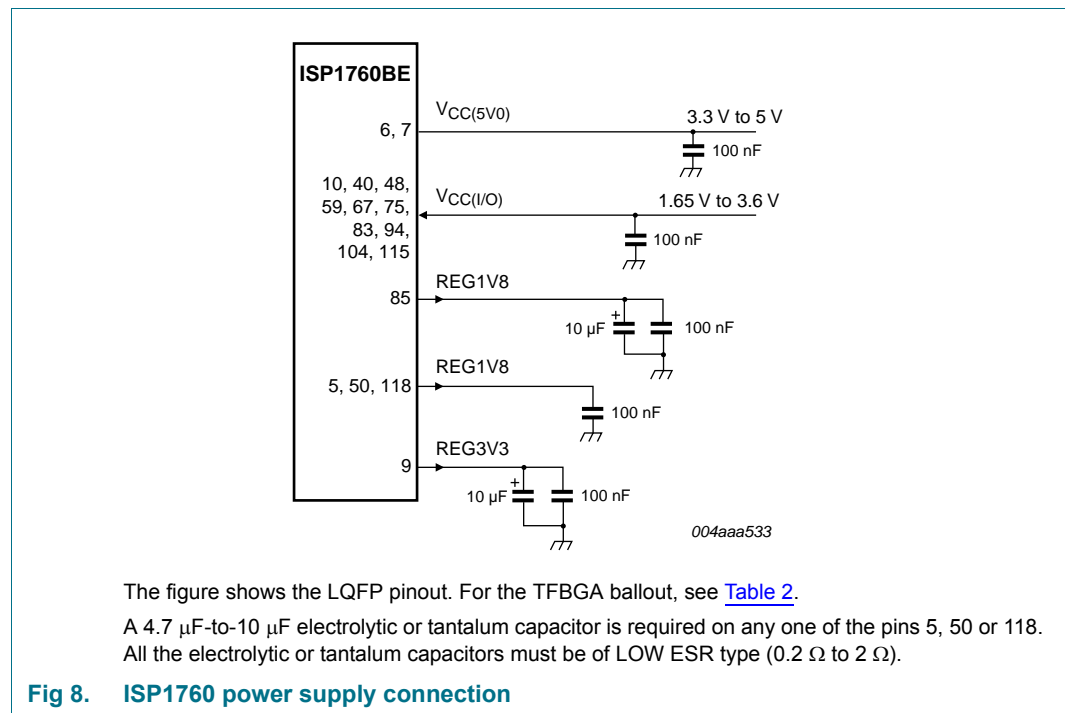

[Figure 9](#) shows the most commonly used power supply connection.

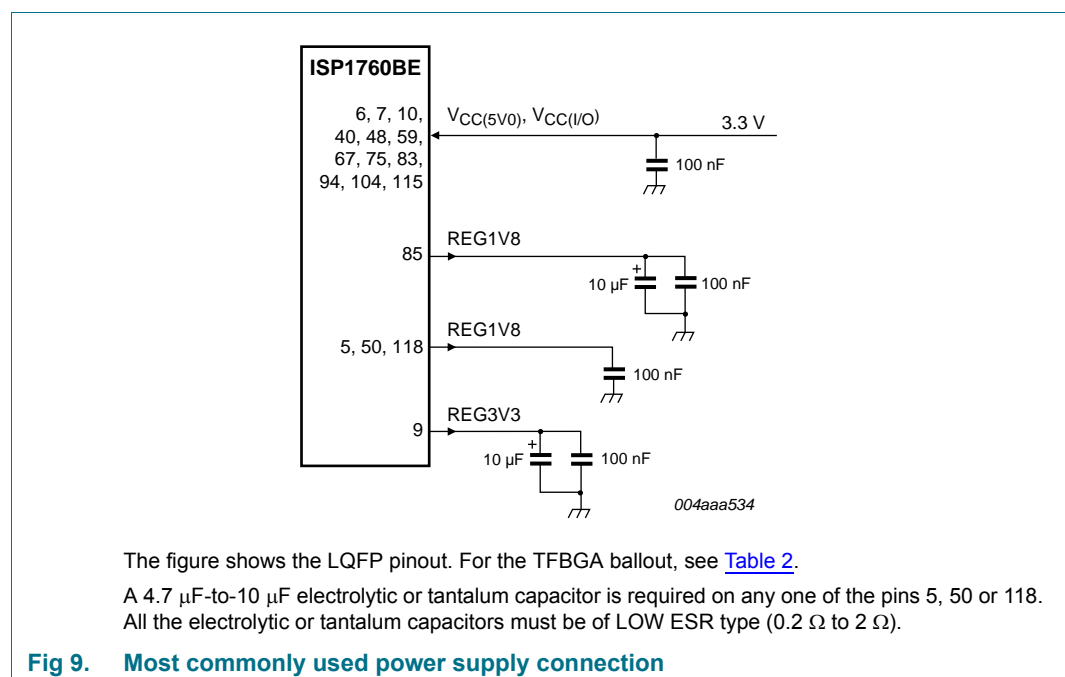

### 7.8.1 Hybrid mode

Table 6 shows the description of hybrid mode.

**Table 6. Hybrid mode**

Voltage	Status
$V_{CC(5V0)}$	off
$V_{CC(I/O)}$	on

In hybrid mode (see Figure 10),  $V_{CC(5V0)}$  can be switched off using an external PMOS transistor, controlled using one of the GPIO pins of the processor. This helps to reduce the suspend current,  $I_{CC(I/O)}$ , below 100  $\mu$ A. If the ISP1760 is used in hybrid mode and  $V_{CC(5V0)}$  is off during suspend, a 2 ms reset pulse is required when power is switched back on, before the resume programming sequence starts.

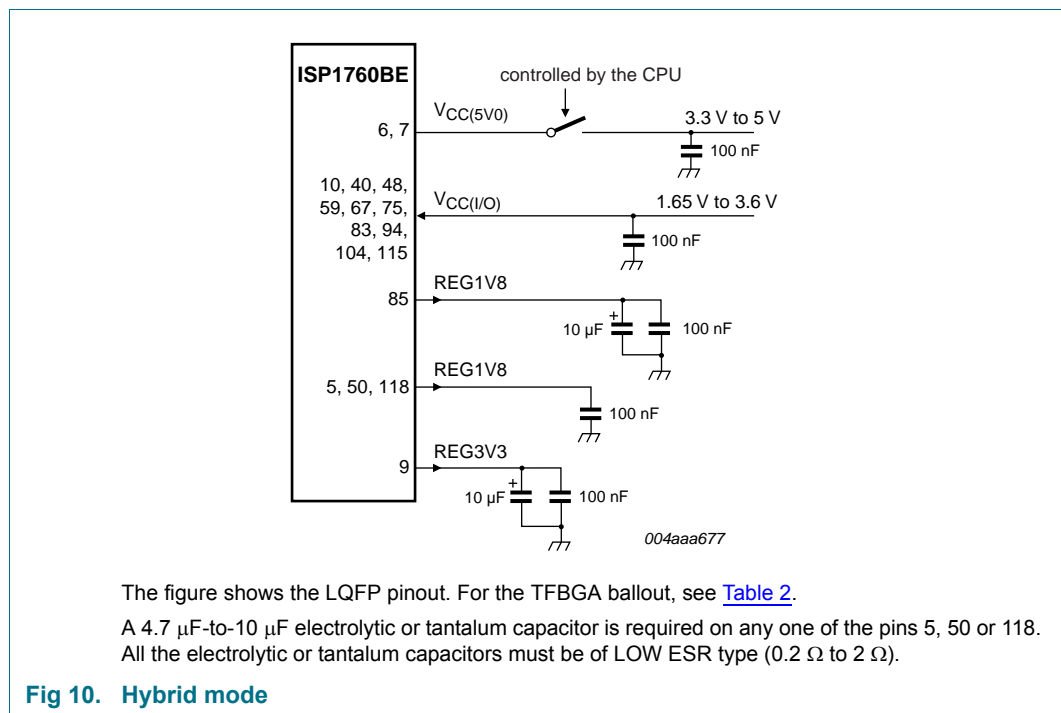

Table 7 shows the status of output pins during hybrid mode.

**Table 7. Pin status in hybrid mode**

Pins	$V_{CC(I/O)}$	$V_{CC(5V0)}$	Status
DATA[31:0], A[17:1], TEST1, TEST2, TEST3, TEST4, TEST5, TEST6, TEST7, DREQ, DACK, IRQ, SUSPEND/WAKEUP_N	on	on	normal
	on	off	high-Z
	off	X	undefined
CS_N, RESET_N, RD_N, WR_N	on	X	input
	off	X	undefined

### 7.9 Power-On Reset (POR)

When  $V_{CC(I/O)}$  is directly connected to the RESET\_N pin, the internal POR pulse width,  $t_{PORP}$ , will typically be 800 ns. The pulse is started when  $V_{CC(5V0)}$  rises above  $V_{TRIP}$  of 1.2 V.

To give a better view of the functionality, [Figure 11](#) shows a possible curve of  $V_{CC(5V0)}$  with dips at  $t_2$  to  $t_3$  and  $t_4$  to  $t_5$ . If the dip at  $t_4$  to  $t_5$  is too short, that is,  $< 11 \mu\text{s}$ , the internal POR pulse will not react and will remain LOW. The internal POR starts with a 1 at  $t_0$ . At  $t_1$ , the detector will see the passing of the trip level and a delay element will add another  $t_{PORP}$  before it drops to 0.

The internal POR pulse will be generated whenever  $V_{CC(5V0)}$  drops below  $V_{TRIP}$  for more than  $11 \mu\text{s}$ .

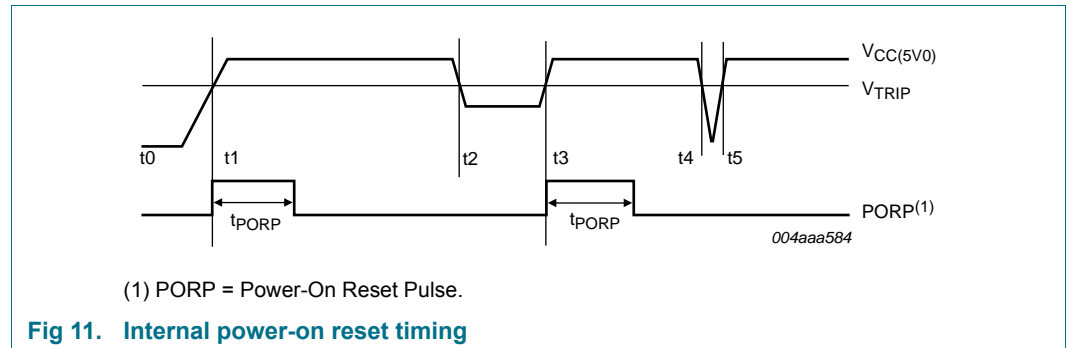

The recommended RESET input pulse length at power-on must be at least 2 ms to ensure that internal clocks are stable.

The RESET\_N pin can be either connected to  $V_{CC(I/O)}$  using the internal POR circuit or externally controlled by the microcontroller, ASIC, and so on. [Figure 12](#) shows the availability of the clock with respect to the external POR.

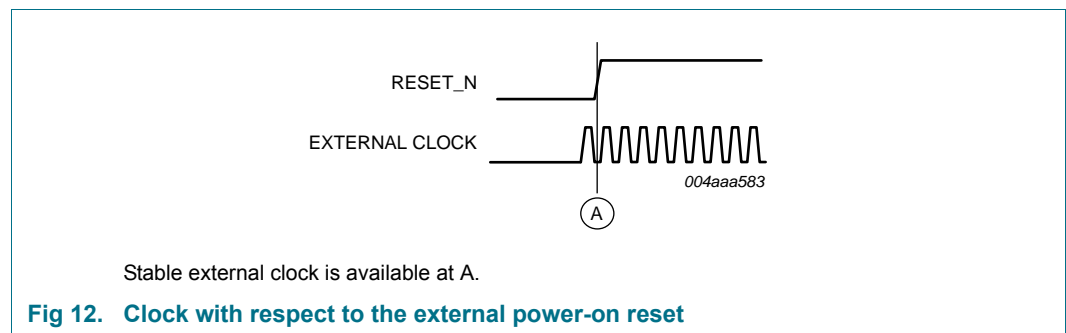

## 8. Registers

[Table 8](#) shows the bit description of the registers.

- All registers range from 0000h to 03FFh. These registers can be read or written as double word, that is 32-bit data. In the case of a 16-bit data bus width, two subsequent accesses are necessary to complete the register read or write cycle.
- Operational registers range from 0000h to 01FFh. Configuration registers range from 0300h to 03FFh.

**Table 8. Register overview**

Address	Register	Reset value	References
<b>EHCI capability registers</b>			
0000h	CAPLENGTH	20h	<a href="#">Section 8.1.1 on page 30</a>
0002h	HCIVERSION	0100h	<a href="#">Section 8.1.2 on page 30</a>
0004h	HCSPARAMS	0000 0011h	<a href="#">Section 8.1.3 on page 30</a>
0008h	HCCPARAMS	0000 0086h	<a href="#">Section 8.1.4 on page 31</a>
<b>EHCI operational registers</b>			
0020h	USBCMD	0008 0B00h	<a href="#">Section 8.2.1 on page 32</a>
0024h	USBSTS	0000 0000h	<a href="#">Section 8.2.2 on page 33</a>
0028h	USBINTR	0000 0000h	<a href="#">Section 8.2.3 on page 34</a>
002Ch	FRINDEX	0000 0000h	<a href="#">Section 8.2.4 on page 34</a>
0060h	CONFIGFLAG	0000 0000h	<a href="#">Section 8.2.5 on page 35</a>
0064h	PORTSC1	0000 2000h	<a href="#">Section 8.2.6 on page 36</a>
0130h	ISO PTD Done Map	0000 0000h	<a href="#">Section 8.2.7 on page 37</a>
0134h	ISO PTD Skip Map	FFFF FFFFh	<a href="#">Section 8.2.8 on page 37</a>
0138h	ISO PTD Last PTD	0000 0000h	<a href="#">Section 8.2.9 on page 38</a>
0140h	INT PTD Done Map	0000 0000h	<a href="#">Section 8.2.10 on page 38</a>
0144h	INT PTD Skip Map	FFFF FFFFh	<a href="#">Section 8.2.11 on page 38</a>
0148h	INT PTD Last PTD	0000 0000h	<a href="#">Section 8.2.12 on page 39</a>
0150h	ATL PTD Done Map	0000 0000h	<a href="#">Section 8.2.13 on page 39</a>
0154h	ATL PTD Skip Map	FFFF FFFFh	<a href="#">Section 8.2.14 on page 39</a>
0158h	ATL PTD Last PTD	0000 0000h	<a href="#">Section 8.2.15 on page 40</a>
0200h to 02FFh	reserved	-	-
<b>Configuration registers</b>			
0300h	HW Mode Control	0000 0100h	<a href="#">Section 8.3.1 on page 40</a>
0304h	Chip ID	0001 1761h	<a href="#">Section 8.3.2 on page 41</a>
0308h	Scratch	0000 0000h	<a href="#">Section 8.3.3 on page 42</a>
030Ch	SW Reset	0000 0000h	<a href="#">Section 8.3.4 on page 42</a>
0330h	DMA Configuration	0000 0000h	<a href="#">Section 8.3.5 on page 42</a>
0334h	Buffer Status	0000 0000h	<a href="#">Section 8.3.6 on page 44</a>
0338h	ATL Done Timeout	0000 0000h	<a href="#">Section 8.3.7 on page 45</a>
033Ch	Memory	0000 0000h	<a href="#">Section 8.3.8 on page 45</a>
0014h	Force Hub Configuration	0000 0000h	<a href="#">Section 8.3.9 on page 46</a>

**Table 8. Register overview ...continued**

Address	Register	Reset value	References
0018h	Force Port Enable	0000 0000h	<a href="#">Section 8.3.10 on page 46</a>
0340h	Edge Interrupt Count	0000 000Fh	<a href="#">Section 8.3.11 on page 47</a>
0344h	DMA Start Address	0000 0000h	<a href="#">Section 8.3.12 on page 48</a>
0354h	Power Down Control	03E8 1BA0h	<a href="#">Section 8.3.13 on page 49</a>
0374h	Port 1 Control	0086 0086h	<a href="#">Section 8.3.14 on page 51</a>
<b>Interrupt registers</b>			
0310h	Interrupt	0000 0000h	<a href="#">Section 8.4.1 on page 52</a>
0314h	Interrupt Enable	0000 0000h	<a href="#">Section 8.4.2 on page 54</a>
0318h	ISO IRQ Mask OR	0000 0000h	<a href="#">Section 8.4.3 on page 55</a>
031Ch	INT IRQ Mask OR	0000 0000h	<a href="#">Section 8.4.4 on page 56</a>
0320h	ATL IRQ Mask OR	0000 0000h	<a href="#">Section 8.4.5 on page 56</a>
0324h	ISO IRQ Mask AND	0000 0000h	<a href="#">Section 8.4.6 on page 56</a>
0328h	INT IRQ Mask AND	0000 0000h	<a href="#">Section 8.4.7 on page 56</a>
032Ch	ATL IRQ Mask AND	0000 0000h	<a href="#">Section 8.4.8 on page 57</a>

## 8.1 EHCI capability registers

### 8.1.1 CAPLENGTH register

The bit description of the Capability Length (CAPLENGTH) register is given in [Table 9](#).

**Table 9. CAPLENGTH - Capability Length register (address 0000h) bit description**

Bit	Symbol	Access	Value	Description
7 to 0	CAPLENGTH[7:0]	R	20h	<b>Capability Length:</b> This is used as an offset. It is added to the register base to find the beginning of the operational register space.

### 8.1.2 HCIVERSION register

[Table 10](#) shows the bit description of the Host Controller Interface Version Number (HCIVERSION) register.

**Table 10. HCIVERSION - Host Controller Interface Version Number register (address 0002h) bit description**

Bit	Symbol	Access	Value	Description
15 to 0	HCIVERSION[15:0]	R	0100h	<b>Host Controller Interface Version Number:</b> It contains a BCD encoding of the version number of the interface to which the host controller interface conforms.

### 8.1.3 HCSPARAMS register

The Host Controller Structural Parameters (HCSPARAMS) register is a set of fields that are structural parameters. The bit allocation is given in [Table 11](#).

**Table 11. HCSPARAMS - Host Controller Structural Parameters register (address 0004h) bit allocation**

Bit	31	30	29	28	27	26	25	24
Symbol	reserved							
Reset	0	0	0	0	0	0	0	0
Access	R	R	R	R	R	R	R	R

Bit	23	22	21	20	19	18	17	16
Symbol	DPN[3:0]				reserved			P_INDICATOR
Reset	0	0	0	0	0	0	0	0
Access	R	R	R	R	R	R	R	R
Bit	15	14	13	12	11	10	9	8
Symbol	N_CC[3:0]				N_PCC[3:0]			
Reset	0	0	0	0	0	0	0	0
Access	R	R	R	R	R	R	R	R
Bit	7	6	5	4	3	2	1	0
Symbol	PRR	reserved		PPC	N_PORTS[3:0]			
Reset	0	0	0	1	0	0	0	1
Access	R	R	R	R	R	R	R	R

**Table 12. HCSPARAMS - Host Controller Structural Parameters register (address 0004h) bit description**

Bit	Symbol	Description <sup>[1]</sup>
31 to 24	-	reserved; write logic 0
23 to 20	DPN[3:0]	<b>Debug Port Number:</b> This field identifies which of the host controller ports is the debug port.
19 to 17	-	reserved; write logic 0
16	P_INDICATOR	<b>Port Indicators:</b> This bit indicates whether the ports support port indicator control.
15 to 12	N_CC[3:0]	<b>Number of Companion Controller:</b> This field indicates the number of companion controllers associated with this Hi-Speed USB host controller.
11 to 8	N_PCC[3:0]	<b>Number of Ports per Companion Controller:</b> This field indicates the number of ports supported per companion host controller.
7	PRR	<b>Port Routing Rules:</b> This field indicates the method used to map ports to companion controllers.
6 to 5	-	reserved; write logic 0
4	PPC	<b>Port Power Control:</b> This field indicates whether the host controller implementation includes port power control.
3 to 0	N_PORTS[3:0]	<b>N_Ports:</b> This field specifies the number of physical downstream ports implemented on this host controller.

[1] For details on register bit description, refer to [Ref. 2 "Enhanced Host Controller Interface Specification for Universal Serial Bus Rev. 1.0"](#).

### 8.1.4 HCCPARAMS register

The Host Controller Capability Parameters (HCCPARAMS) register is a four-byte register, and the bit allocation is given in [Table 13](#).

**Table 13. HCCPARAMS - Host Controller Capability Parameters register (address 0008h) bit allocation**

Bit	31	30	29	28	27	26	25	24
Symbol	reserved							
Reset	0	0	0	0	0	0	0	0
Access	R	R	R	R	R	R	R	R

Bit	23	22	21	20	19	18	17	16
Symbol	reserved							
Reset	0	0	0	0	0	0	0	0
Access	R	R	R	R	R	R	R	R
Bit	15	14	13	12	11	10	9	8
Symbol	EECP[7:0]							
Reset	0	0	0	0	0	0	0	0
Access	R	R	R	R	R	R	R	R
Bit	7	6	5	4	3	2	1	0
Symbol	IST[3:0]			reserved		ASPC	PFLF	reserved
Reset	1	0	0	0	0	1	1	0
Access	R	R	R	R	R	R	R	R

**Table 14. HCCPARAMS - Host Controller Capability Parameters register (address 0008h) bit description**

Bit	Symbol	Description <sup>[1]</sup>
31 to 16	-	reserved; write logic 0
15 to 8	EECP[7:0]	<b>EHCI Extended Capabilities Pointer:</b> Default = implementation dependent. This optional field indicates the existence of a capabilities list.
7 to 4	IST[3:0]	<b>Isochronous Scheduling Threshold:</b> Default = implementation dependent. This field indicates, relative to the current position of the executing host controller, where software can reliably update the isochronous schedule.
3	-	reserved; write logic 0
2	ASPC	<b>Asynchronous Schedule Park Capability:</b> Default = implementation dependent. If this bit is set to logic 1, the host controller supports the park feature for high-speed Transfer Descriptors in the Asynchronous Schedule.
1	PFLF	<b>Programmable Frame List Flag:</b> Default = implementation dependent. If this bit is cleared, the system software must use a frame list length of 1024 elements with this host controller.  If PFLF is set, the system software can specify and use a smaller frame list and configure the host through the Frame List Size (FLS) field of the USBCMD register.
0	-	reserved; write logic 0

[1] For details on register bit description, refer to [Ref. 2 "Enhanced Host Controller Interface Specification for Universal Serial Bus Rev. 1.0"](#).

## 8.2 EHCI operational registers

### 8.2.1 USBCMD register

The USB Command (USBCMD) register indicates the command to be executed by the serial host controller. Writing to this register causes a command to be executed. [Table 15](#) shows the USBCMD register bit allocation.



**Table 15. USBCMD - USB Command register (address 0020h) bit allocation**

Bit	31	30	29	28	27	26	25	24	
Symbol	reserved <sup>[1]</sup>								
Reset	0	0	0	0	0	0	0	0	
Access	R/W	R/W	R/W	R/W	R/W	R/W	R/W	R/W	
Bit	23	22	21	20	19	18	17	16	
Symbol	reserved <sup>[1]</sup>								
Reset	0	0	0	0	1	0	0	0	
Access	R/W	R/W	R/W	R/W	R/W	R/W	R/W	R/W	
Bit	15	14	13	12	11	10	9	8	
Symbol	reserved <sup>[1]</sup>								
Reset	0	0	0	0	1	0	1	1	
Access	R/W	R/W	R/W	R/W	R/W	R/W	R/W	R/W	
Bit	7	6	5	4	3	2	1	0	
Symbol	LHCR	reserved <sup>[1]</sup>					HCRESET	RS	
Reset	0	0	0	0	0	0	0	0	
Access	R/W	R/W	R/W	R/W	R/W	R/W	R/W	R/W	

[1] The reserved bits should always be written with the reset value.

**Table 16. USBCMD - USB Command register (address 0020h) bit description**

Bit	Symbol	Description <sup>[1]</sup>
31 to 8	-	reserved
7	LHCR	<b>Light Host Controller Reset</b> (optional): If implemented, it allows the driver software to reset the EHCI controller without affecting the state of the ports or the relationship to the companion host controllers. If not implemented, a read of this field will always return logic 0.
6 to 2	-	reserved
1	HCRESET	<b>Host Controller Reset</b> : This control bit is used by the software to reset the host controller.
0	RS	<b>Run/Stop</b> : 1 = Run, 0 = Stop. When set, the host controller executes the schedule.

[1] For details on register bit description, refer to [Ref. 2 "Enhanced Host Controller Interface Specification for Universal Serial Bus Rev. 1.0"](#).

### 8.2.2 USBSTS register

The USB Status (USBSTS) register indicates pending interrupts and various states of the host controller. The status resulting from a transaction on the serial bus is not indicated in this register. Software clears register bits by writing ones to them. The bit allocation is given in [Table 17](#).

**Table 17. USBSTS - USB Status register (address 0024h) bit allocation**

Bit	31	30	29	28	27	26	25	24
Symbol	reserved <sup>[1]</sup>							
Reset	0	0	0	0	0	0	0	0
Access	R/W	R/W	R/W	R/W	R/W	R/W	R/W	R/W

Bit	23	22	21	20	19	18	17	16
Symbol	reserved <sup>[1]</sup>							
Reset	0	0	0	0	0	0	0	0
Access	R/W	R/W	R/W	R/W	R/W	R/W	R/W	R/W
Bit	15	14	13	12	11	10	9	8
Symbol	reserved <sup>[1]</sup>							
Reset	0	0	0	0	0	0	0	0
Access	R/W	R/W	R/W	R/W	R/W	R/W	R/W	R/W
Bit	7	6	5	4	3	2	1	0
Symbol	reserved <sup>[1]</sup>				FLR	PCD	reserved <sup>[1]</sup>	
Reset	0	0	0	0	0	0	0	0
Access	R/W	R/W	R/W	R/W	R/W	R/W	R/W	R/W

[1] The reserved bits should always be written with the reset value.

**Table 18. USBSTS - USB Status register (address 0024h) bit description**

Bit	Symbol	Description <sup>[1]</sup>
31 to 4	-	reserved; write logic 0
3	FLR	<b>Frame List Rollover:</b> The host controller sets this bit to logic 1 when the frame list Index rolls over from its maximum value to zero.
2	PCD	<b>Port Change Detect:</b> The host controller sets this bit to logic 1 when any port, where the PO bit is cleared, has a change to a one or a FPR bit changes to a one as a result of a J-K transition detected on a suspended port.
1 to 0	-	reserved

[1] For details on register bit description, refer to [Ref. 2 "Enhanced Host Controller Interface Specification for Universal Serial Bus Rev. 1.0"](#).

### 8.2.3 USBINTR register

The USB Interrupt (USBINTR) register is a read or write register located at 0028h. All the bits in this register are reserved.

### 8.2.4 FRINDEX register

The Frame Index (FRINDEX) register is used by the host controller to index into the periodic frame list. The register updates every 125  $\mu$ s (once each microframe). Bits n to 3 are used to select a particular entry in the periodic frame list during periodic schedule execution. The number of bits used for the index depends on the size of the frame list as set by the system software in the Frame List Size (FLS) field of the USBCMD register. This register must be written as a double word. A word-only write (16-bit mode) produces undefined results. A write to this register while the RS (Run/Stop) bit is set produces undefined results. Writes to this register also affect the SOF value. The bit allocation is given in [Table 19](#).

**Table 19. FRINDEX - Frame Index register (address: 002Ch) bit allocation**

Bit	31	30	29	28	27	26	25	24
Symbol	reserved <sup>[1]</sup>							
Reset	0	0	0	0	0	0	0	0
Access	R/W	R/W	R/W	R/W	R/W	R/W	R/W	R/W

<b>Bit</b>	<b>23</b>	<b>22</b>	<b>21</b>	<b>20</b>	<b>19</b>	<b>18</b>	<b>17</b>	<b>16</b>
<b>Symbol</b>	reserved <sup>[1]</sup>							
<b>Reset</b>	0	0	0	0	0	0	0	0
<b>Access</b>	R/W	R/W	R/W	R/W	R/W	R/W	R/W	R/W
<b>Bit</b>	<b>15</b>	<b>14</b>	<b>13</b>	<b>12</b>	<b>11</b>	<b>10</b>	<b>9</b>	<b>8</b>
<b>Symbol</b>	reserved <sup>[1]</sup>		FRINDEX[13:8]					
<b>Reset</b>	0	0	0	0	0	0	0	0
<b>Access</b>	R/W	R/W	R/W	R/W	R/W	R/W	R/W	R/W
<b>Bit</b>	<b>7</b>	<b>6</b>	<b>5</b>	<b>4</b>	<b>3</b>	<b>2</b>	<b>1</b>	<b>0</b>
<b>Symbol</b>	FRINDEX[7:0]							
<b>Reset</b>	0	0	0	0	0	0	0	0
<b>Access</b>	R/W	R/W	R/W	R/W	R/W	R/W	R/W	R/W

[1] The reserved bits should always be written with the reset value.

**Table 20. FRINDEX - Frame Index register (address: 002Ch) bit description**

Bit	Symbol	Description <sup>[1]</sup>
31 to 14	-	reserved
13 to 0	FRINDEX [13:0]	<b>Frame Index:</b> Bits in this register are used for the frame number in the SOF packet and as the index into the frame list. The value in this register increments at the end of each time frame. For example, microframe.

[1] For details on register bit description, refer to [Ref. 2 “Enhanced Host Controller Interface Specification for Universal Serial Bus Rev. 1.0”](#).

### 8.2.5 CONFIGFLAG register

The bit allocation of the Configure Flag (CONFIGFLAG) register is given in [Table 21](#).

**Table 21. CONFIGFLAG - Configure Flag register (address 0060h) bit allocation**

<b>Bit</b>	<b>31</b>	<b>30</b>	<b>29</b>	<b>28</b>	<b>27</b>	<b>26</b>	<b>25</b>	<b>24</b>
<b>Symbol</b>	reserved <sup>[1]</sup>							
<b>Reset</b>	0	0	0	0	0	0	0	0
<b>Access</b>	R/W	R/W	R/W	R/W	R/W	R/W	R/W	R/W
<b>Bit</b>	<b>23</b>	<b>22</b>	<b>21</b>	<b>20</b>	<b>19</b>	<b>18</b>	<b>17</b>	<b>16</b>
<b>Symbol</b>	reserved <sup>[1]</sup>							
<b>Reset</b>	0	0	0	0	0	0	0	0
<b>Access</b>	R/W	R/W	R/W	R/W	R/W	R/W	R/W	R/W
<b>Bit</b>	<b>15</b>	<b>14</b>	<b>13</b>	<b>12</b>	<b>11</b>	<b>10</b>	<b>9</b>	<b>8</b>
<b>Symbol</b>	reserved <sup>[1]</sup>							
<b>Reset</b>	0	0	0	0	0	0	0	0
<b>Access</b>	R/W	R/W	R/W	R/W	R/W	R/W	R/W	R/W
<b>Bit</b>	<b>7</b>	<b>6</b>	<b>5</b>	<b>4</b>	<b>3</b>	<b>2</b>	<b>1</b>	<b>0</b>
<b>Symbol</b>	reserved <sup>[1]</sup>							CF
<b>Reset</b>	0	0	0	0	0	0	0	0
<b>Access</b>	R/W	R/W	R/W	R/W	R/W	R/W	R/W	R/W

[1] The reserved bits should always be written with the reset value.

**Table 22. CONFIGFLAG - Configure Flag register (address 0060h) bit description**

Bit	Symbol	Description <sup>[1]</sup>
31 to 1	-	reserved
0	CF	<b>Configure Flag:</b> The host software sets this bit as the last action when it is configuring the host controller. This bit controls the default port-routing control logic.

[1] For details on register bit description, refer to [Ref. 2 "Enhanced Host Controller Interface Specification for Universal Serial Bus Rev. 1.0"](#).

### 8.2.6 PORTSC1 register

The Port Status and Control (PORTSC) register (bit allocation: [Table 23](#)) is in the power well. It is reset by hardware only when the auxiliary power is initially applied or in response to a host controller reset. The initial conditions of a port are:

- No peripheral connected
- Port disabled

If the port has power control, software cannot change the state of the port until it sets port power bits. Software must not attempt to change the state of the port until the power is stable on the port (maximum delay is 20 ms from the transition).

**Table 23. PORTSC1 - Port Status and Control 1 register (address 0064h) bit allocation**

Bit	31	30	29	28	27	26	25	24
Symbol	reserved <sup>[1]</sup>							
Reset	0	0	0	0	0	0	0	0
Access	R/W	R/W	R/W	R/W	R/W	R/W	R/W	R/W
Bit	23	22	21	20	19	18	17	16
Symbol	reserved <sup>[1]</sup>				PTC[3:0]			
Reset	0	0	0	0	0	0	0	0
Access	R/W	R/W	R/W	R/W	R/W	R/W	R/W	R/W
Bit	15	14	13	12	11	10	9	8
Symbol	PIC[1:0]		PO	PP	LS[1:0]		reserved <sup>[1]</sup>	PR
Reset	0	0	1	0	0	0	0	0
Access	R	R	R/W	R/W	R/W	R/W	R/W	R
Bit	7	6	5	4	3	2	1	0
Symbol	SUSP	FPR	reserved <sup>[1]</sup>			PED	ECSC	ECCS
Reset	0	0	0	0	0	0	0	0
Access	R/W	R/W	R/W	R/W	R/W	R/W	R/W	R

[1] The reserved bits should always be written with the reset value.

**Table 24. PORTSC1 - Port Status and Control 1 register (address 0064h) bit description**

Bit	Symbol	Description <sup>[1]</sup>
31 to 20	-	reserved
19 to 16	PTC[3:0]	<b>Port Test Control:</b> When this field is zero, the port is not operating in test mode. A nonzero value indicates that it is operating in test mode indicated by the value.
15 to 14	PIC[1:0]	<b>Port Indicator Control:</b> Writing to this field has no effect if the P_INDICATOR bit in the HCSPARAMS register is logic 0. For a description on how these bits are implemented, refer to <a href="#">Ref. 1 "Universal Serial Bus Specification Rev. 2.0"</a> . <sup>[2]</sup>
13	PO	<b>Port Owner:</b> This bit unconditionally goes to logic 0 when the configured bit in the CONFIGFLAG register makes a logic 0 to logic 1 transition. This bit unconditionally goes to logic 1 whenever the configured bit is logic 0.
12	PP	<b>Port Power:</b> The function of this bit depends on the value of the PPC (Port Power Control) field in the HCSPARAMS register.
11 to 10	LS[1:0]	<b>Line Status:</b> This field reflects the current logical levels of the DP (bit 11) and DM (bit 10) signal lines.
9	-	reserved
8	PR	<b>Port Reset:</b> Logic 1 means the port is in the reset state. Logic 0 means the port is not in reset. <sup>[2]</sup>
7	SUSP	<b>Suspend:</b> Logic 1 means the port is in the suspend state. Logic 0 means the port is not suspended. <sup>[2]</sup>
6	FPR	<b>Force Port Resume:</b> Logic 1 means resume detected or driven on the port. Logic 0 means no resume (K-state) detected or driven on the port. <sup>[2]</sup>
5 to 3	-	reserved
2	PED	<b>Port Enabled/Disabled:</b> Logic 1 means enable. Logic 0 means disable. <sup>[2]</sup>
1	ECSC	<b>Connect Status Change:</b> Logic 1 means change in ECCS. Logic 0 means no change. <sup>[2]</sup>
0	ECCS	<b>Current Connect Status:</b> Logic 1 indicates a device is present on the port. Logic 0 indicates no device is present. <sup>[2]</sup>

[1] For details on register bit description, refer to [Ref. 2 "Enhanced Host Controller Interface Specification for Universal Serial Bus Rev. 1.0"](#).

[2] These fields read logic 0, if the PP (Port Power) bit in register PORTSC1 is logic 0.

### 8.2.7 ISO PTD Done Map register

The bit description of the register is given in [Table 25](#).

**Table 25. ISO PTD Done Map register (address 0130h) bit description**

Bit	Symbol	Access	Value	Description
31 to 0	ISO_PTD_DONE_MAP[31:0]	R	0000 0000h	<b>ISO PTD Done Map:</b> Done map for each of the 32 PTDs for the ISO transfer

This register represents a direct map of the done status of the 32 PTDs. The bit corresponding to a certain PTD will be set to logic 1 as soon as that PTD execution is completed. Reading the Done Map register will clear all the bits that are set to logic 1, and the next reading will reflect the updated status of new executed PTDs.

### 8.2.8 ISO PTD Skip Map register

[Table 26](#) shows the bit description of the register.

**Table 26. ISO PTD Skip Map register (address 0134h) bit description**

Bit	Symbol	Access	Value	Description
31 to 0	ISO_PTD_SKIP_MAP[31:0]	R/W	FFFF FFFFh	<b>ISO PTD Skip Map:</b> Skip map for each of the 32 PTDs for the ISO transfer.

When a bit in the PTD Skip Map is set to logic 1 that PTD will be skipped although its V bit may be set. The information in that PTD is not processed. For example, NextPTDPointer will not affect the order of processing of PTDs. The Skip bit should not normally be set on the position indicated by NextPTDPointer.

### 8.2.9 ISO PTD Last PTD register

[Table 27](#) shows the bit description of the ISO PTD Last PTD register.

**Table 27. ISO PTD Last PTD register (address 0138h) bit description**

Bit	Symbol	Access	Value	Description
31 to 0	ISO_PTD_LAST_PTD[31:0]	R/W	0000 0000h	<b>ISO PTD last PTD:</b> Last PTD of the 32 PTDs is indicated by the 32 bitmap. <b>1h</b> — One PTD in ISO <b>2h</b> — Two PTDs in ISO <b>4h</b> — Three PTDs in ISO

Once the LastPTD bit corresponding to a PTD is set, this will be the last PTD processed (checking V = 1) in that PTD category. Subsequently, the process will restart with the first PTD of that group. This is useful to reduce the time in which all the PTDs, the respective memory space, would be checked, especially if only a few PTDs are defined. The LastPTD bit must be normally set to a higher position than any other position indicated by the NextPTDPointer from an active PTD.

### 8.2.10 INT PTD Done Map register

The bit description of the register is given in [Table 28](#).

**Table 28. INT PTD Done Map register (address 0140h) bit description**

Bit	Symbol	Access	Value	Description
31 to 0	INT_PTD_DONE_MAP[31:0]	R	0000 0000h	<b>INT PTD Done Map:</b> Done map for each of the 32 PTDs for the INT transfer

This register represents a direct map of the done status of the 32 PTDs. The bit corresponding to a certain PTD will be set to logic 1 as soon as that PTD execution is completed. Reading the Done Map register will clear all the bits that are set to logic 1, and the next reading will reflect the updated status of new executed PTDs.

### 8.2.11 INT PTD Skip Map register

[Table 29](#) shows the bit description of the INT PTD Skip Map register.

**Table 29. INT PTD Skip Map register (address 0144h) bit description**

Bit	Symbol	Access	Value	Description
31 to 0	INT_PTD_SKIP_MAP[31:0]	R/W	FFFF FFFFh	<b>INT PTD Skip Map:</b> Skip map for each of the 32 PTDs for the INT transfer

When a bit in the PTD Skip Map is set to logic 1 that PTD will be skipped although its V bit may be set. The information in that PTD is not processed. For example, NextPTDPointer will not affect the order of processing of PTDs. The Skip bit must not be normally set on the position indicated by NextPTDPointer.

### 8.2.12 INT PTD Last PTD register

The bit description of the register is given in [Table 30](#).

**Table 30. INT PTD Last PTD register (address 0148h) bit description**

Bit	Symbol	Access	Value	Description
31 to 0	INT_PTD_LAST_PTD[31:0]	R/W	0000 0000h	<b>INT PTD Last PTD:</b> Last PTD of the 32 PTDs as indicated by the 32 bitmap. <b>1h</b> — One PTD in INT <b>2h</b> — Two PTDs in INT <b>3h</b> — Three PTDs in INT

Once the LastPTD bit corresponding to a PTD is set, this will be the last PTD processed (checking V = 1) in that PTD category. Subsequently, the process will restart with the first PTD of that group. This is useful to reduce the time in which all the PTDs, the respective memory space, would be checked, especially if only a few PTDs are defined. The LastPTD bit must be normally set to a higher position than any other position indicated by the NextPTDPointer from an active PTD.

### 8.2.13 ATL PTD Done Map register

[Table 31](#) shows the bit description of the ATL PTD Done Map register.

**Table 31. ATL PTD Done Map register (address 0150h) bit description**

Bit	Symbol	Access	Value	Description
31 to 0	ATL_PTD_DONE_MAP[31:0]	R	0000 0000h	<b>ATL PTD Done Map:</b> Done map for each of the 32 PTDs for the ATL transfer

This register represents a direct map of the done status of the 32 PTDs. The bit corresponding to a certain PTD will be set to logic 1 as soon as that PTD execution is completed. Reading the Done Map register will clear all the bits that are set to logic 1, and the next reading will reflect the updated status of new executed PTDs.

### 8.2.14 ATL PTD Skip Map register

The bit description of the register is given in [Table 32](#).

**Table 32. ATL PTD Skip Map register (address 0154h) bit description**

Bit	Symbol	Access	Value	Description
31 to 0	ATL_PTD_SKIP_MAP[31:0]	R/W	FFFF FFFFh	<b>ATL PTD Skip Map:</b> Skip map for each of the 32 PTDs for the ATL transfer

When a bit in the PTD Skip Map is set to logic 1 that PTD will be skipped although its V bit may be set. The information in that PTD is not processed. For example, NextPTDPointer will not affect the order of processing of PTDs. The Skip bit must not normally be set on the position indicated by NextPTDPointer.

### 8.2.15 ATL PTD Last PTD register

The bit description of the ATL PTD Last PTD register is given in [Table 33](#).

**Table 33. ATL PTD Last PTD register (address 0158h) bit description**

Bit	Symbol	Access	Value	Description
31 to 0	ATL_PTD_LAST_PTD[31:0]	R/W	0000 0000h	<b>ATL PTD Last PTD:</b> Last PTD of the 32 PTDs as indicated by the 32 bitmap. <b>1h</b> — One PTD in ATL <b>2h</b> — Two PTDs in ATL <b>4h</b> — Three PTDs in ATL

Once the LastPTD bit corresponding to a PTD is set, this will be the last PTD processed (checking  $V = 1$ ) in that PTD category. Subsequently, the process will restart with the first PTD of that group. This is useful to reduce the time in which all the PTDs, the respective memory space, would be checked, especially if only a few PTDs are defined. The LastPTD bit must normally be set to a higher position than any other position indicated by the NextPTDPointer from an active PTD.

## 8.3 Configuration registers

### 8.3.1 HW Mode Control register

[Table 34](#) shows the bit allocation of the register.

**Table 34. HW Mode Control - Hardware Mode Control register (address 0300h) bit allocation**

Bit	31	30	29	28	27	26	25	24
<b>Symbol</b>	ALL_ATX_RESET	reserved <sup>[1]</sup>						
<b>Reset</b>	0	0	0	0	0	0	0	0
<b>Access</b>	R/W	R/W	R/W	R/W	R/W	R/W	R/W	R/W
Bit	23	22	21	20	19	18	17	16
<b>Symbol</b>	reserved <sup>[1]</sup>							
<b>Reset</b>	0	0	0	0	0	0	0	0
<b>Access</b>	R/W	R/W	R/W	R/W	R/W	R/W	R/W	R/W
Bit	15	14	13	12	11	10	9	8
<b>Symbol</b>	ANA_DIGI_OC	reserved <sup>[1]</sup>						DATA_BUS_WIDTH
<b>Reset</b>	0	0	0	0	0	0	0	1
<b>Access</b>	R/W	R/W	R/W	R/W	R/W	R/W	R/W	R/W
Bit	7	6	5	4	3	2	1	0
<b>Symbol</b>	reserved	DACK_POL	DREQ_POL	reserved <sup>[1]</sup>		INTR_POL	INTR_LEVEL	GLOBAL_INTR_EN
<b>Reset</b>	0	0	0	0	0	0	0	0
<b>Access</b>	R/W	R/W	R/W	R/W	R/W	R/W	R/W	R/W

[1] The reserved bits should always be written with the reset value.



**Table 35. HW Mode Control - Hardware Mode Control register (address 0300h) bit description**

Bit	Symbol	Description
31	ALL_ATX_RESET	<b>All ATX Reset:</b> For debugging purposes (not used normally). 1 — Enable reset, then write back logic 0 0 — No reset
30 to 16	-	reserved; write logic 0
15	ANA_DIGI_OC	<b>Analog Digital Overcurrent:</b> This bit selects analog or digital overcurrent detection on pins OC1_N, OC2_N and OC3_N. 0 — Digital overcurrent 1 — Analog overcurrent
14 to 9	-	reserved; write logic 0
8	DATA_BUS_WIDTH	<b>Data Bus Width:</b> 0 — Defines a 16-bit data bus width 1 — Sets a 32-bit data bus width
7	-	reserved; write logic 0
6	DACK_POL	<b>DACK Polarity:</b> 1 — Indicates that the DACK input is active HIGH 0 — Indicates active LOW
5	DREQ_POL	<b>DREQ Polarity:</b> 1 — Indicates that the DREQ output is active HIGH 0 — Indicates active LOW
4 to 3	-	reserved; write logic 0
2	INTR_POL	<b>Interrupt Polarity:</b> 0 — Active LOW 1 — Active HIGH
1	INTR_LEVEL	<b>Interrupt Level:</b> 0 — INT is level triggered. 1 — INT is edge triggered. A pulse of certain width is generated.
0	GLOBAL_INTR_EN	<b>Global Interrupt Enable:</b> This bit must be set to logic 1 to enable the IRQ signal assertion. 0 — IRQ assertion is disabled. IRQ will never be asserted, regardless of other settings or IRQ events. 1 — IRQ assertion is enabled. IRQ will be asserted according to the Interrupt Enable register, and events setting and occurrence.

### 8.3.2 Chip ID register

Read this register to get the ID of the ISP1760. The upper word of the register contains the hardware version number and the lower word contains the chip ID. [Table 36](#) shows the bit description of the register.

**Table 36. Chip ID - Chip Identifier register (address 0304h) bit description**

Bit	Symbol	Access	Value	Description
31 to 0	CHIPID[31:0]	R	0001 1761h	<b>Chip ID:</b> This register represents the hardware version number (0001h) and the chip ID (1761h). <b>Remark:</b> The chip ID is for internal use to identify the ISP176x product family.

### 8.3.3 Scratch register

This register is for testing and debugging purposes only. The value read back must be the same as the value that was written. The bit description of this register is given in [Table 37](#).

**Table 37. Scratch register (address 0308h) bit description**

Bit	Symbol	Access	Value	Description
31 to 0	SCRATCH[31:0]	R/W	0000 0000h	<b>Scratch:</b> For testing and debugging purposes

### 8.3.4 SW Reset register

[Table 38](#) shows the bit allocation of the register.

**Table 38. SW Reset - Software Reset register (address 030Ch) bit allocation**

Bit	31	30	29	28	27	26	25	24
<b>Symbol</b>	reserved <sup>[1]</sup>							
<b>Reset</b>	0	0	0	0	0	0	0	0
<b>Access</b>	R/W	R/W	R/W	R/W	R/W	R/W	R/W	R/W
Bit	23	22	21	20	19	18	17	16
<b>Symbol</b>	reserved <sup>[1]</sup>							
<b>Reset</b>	0	0	0	0	0	0	0	0
<b>Access</b>	R/W	R/W	R/W	R/W	R/W	R/W	R/W	R/W
Bit	15	14	13	12	11	10	9	8
<b>Symbol</b>	reserved <sup>[1]</sup>							
<b>Reset</b>	0	0	0	0	0	0	0	0
<b>Access</b>	R/W	R/W	R/W	R/W	R/W	R/W	R/W	R/W
Bit	7	6	5	4	3	2	1	0
<b>Symbol</b>	reserved <sup>[1]</sup>						RESET_ HC	RESET_ ALL
<b>Reset</b>	0	0	0	0	0	0	0	0
<b>Access</b>	R/W	R/W	R/W	R/W	R/W	R/W	R/W	R/W

[1] The reserved bits should always be written with the reset value.

**Table 39. SW Reset - Software Reset register (address 030Ch) bit description**

Bit	Symbol	Description
31 to 2	-	reserved; write logic 0
1	RESET_HC	<b>Reset Host Controller:</b> Reset only the host controller-specific registers (only registers with address 300h and below). <b>0</b> — No reset <b>1</b> — Enable reset
0	RESET_ALL	<b>Reset All:</b> Reset all the host controller and CPU interface registers. <b>0</b> — No reset <b>1</b> — Enable reset

### 8.3.5 DMA Configuration register

The bit allocation of the DMA Configuration register is given in [Table 40](#).

**Table 40. DMA Configuration register (address 0330h) bit allocation**

Bit	31	30	29	28	27	26	25	24
Symbol	DMA_COUNTER[23:16]							
Reset	0	0	0	0	0	0	0	0
Access	R/W	R/W	R/W	R/W	R/W	R/W	R/W	R/W
Bit	23	22	21	20	19	18	17	16
Symbol	DMA_COUNTER[15:8]							
Reset	0	0	0	0	0	0	0	0
Access	R/W	R/W	R/W	R/W	R/W	R/W	R/W	R/W
Bit	15	14	13	12	11	10	9	8
Symbol	DMA_COUNTER[7:0]							
Reset	0	0	0	0	0	0	0	0
Access	R/W	R/W	R/W	R/W	R/W	R/W	R/W	R/W
Bit	7	6	5	4	3	2	1	0
Symbol	reserved <sup>[1]</sup>				BURST_LEN[1:0]		ENABLE_DMA	DMA_READ_WRITE_SEL
Reset	0	0	0	0	0	0	0	0
Access	R/W	R/W	R/W	R/W	R/W	R/W	R/W	R/W

[1] The reserved bits should always be written with the reset value.

**Table 41. DMA Configuration register (address 0330h) bit description**

Bit	Symbol	Description
31 to 8	DMA_COUNTER[23:0]	<b>DMA Counter:</b> The number of bytes to be transferred (read or write).  <b>Remark:</b> Different number of bursts will be generated for the same transfer length programmed in 16-bit and 32-bit modes because DMA_COUNTER is in number of bytes.
7 to 4	-	reserved
3 to 2	BURST_LEN[1:0]	<b>DMA Burst Length:</b> <b>00</b> — Single DMA burst <b>01</b> — 4-cycle DMA burst <b>10</b> — 8-cycle DMA burst <b>11</b> — 16-cycle DMA burst
1	ENABLE_DMA	<b>Enable DMA:</b> <b>0</b> — Terminate DMA <b>1</b> — Enable DMA
0	DMA_READ_WRITE_SEL	<b>DMA Read/Write Select:</b> Indicates if the DMA operation is a write or read to or from the ISP1760. <b>0</b> — DMA write to the ISP1760 internal RAM is set <b>1</b> — DMA read from the ISP1760 internal RAM

### 8.3.6 Buffer Status register

The Buffer Status register is used to indicate the HC that a particular PTD buffer (that is, ATL, INT and ISO) contains at least one PTD that must be scheduled. Once software sets the Buffer Filled bit of a particular transfer in the Buffer Status register, the HC will start traversing through PTD headers that are not marked for skipping and are valid PTDs.

**Remark:** Software can set these bits during the initialization.

[Table 42](#) shows the bit allocation of the Buffer Status register.

**Table 42. Buffer Status register (address 0334h) bit allocation**

Bit	31	30	29	28	27	26	25	24	
Symbol	reserved <sup>[1]</sup>								
Reset	0	0	0	0	0	0	0	0	
Access	R/W	R/W	R/W	R/W	R/W	R/W	R/W	R/W	
Bit	23	22	21	20	19	18	17	16	
Symbol	reserved <sup>[1]</sup>								
Reset	0	0	0	0	0	0	0	0	
Access	R/W	R/W	R/W	R/W	R/W	R/W	R/W	R/W	
Bit	15	14	13	12	11	10	9	8	
Symbol	reserved <sup>[1]</sup>								
Reset	0	0	0	0	0	0	0	0	
Access	R/W	R/W	R/W	R/W	R/W	R/W	R/W	R/W	
Bit	7	6	5	4	3	2	1	0	
Symbol	reserved <sup>[1]</sup>					ISO_BUF_ FILL	INT_BUF_ FILL	ATL_BUF_ FILL	
Reset	0	0	0	0	0	0	0	0	
Access	R/W	R/W	R/W	R/W	R/W	R/W	R/W	R/W	

[1] The reserved bits should always be written with the reset value.

**Table 43. Buffer Status register (address 0334h) bit description**

Bit	Symbol	Description
31 to 3	-	reserved
2	ISO_BUF_ FILL	<b>ISO Buffer Filled:</b> <b>1</b> — Indicates one of the ISO PTDs is filled, and the ISO PTD area will be processed. <b>0</b> — Indicates there is no PTD in this area. Therefore, processing of the ISO PTDs will completely be skipped.
1	INT_BUF_ FILL	<b>INT Buffer Filled:</b> <b>1</b> — Indicates one of the INT PTDs is filled, and the INT PTD area will be processed. <b>0</b> — Indicates there is no PTD in this area. Therefore, processing of the INT PTDs will completely be skipped.

**Table 43. Buffer Status register (address 0334h) bit description ...continued**

Bit	Symbol	Description
0	ATL_BUF_FILL	<b>ATL Buffer Filled:</b> <b>1</b> — Indicates one of the ATL PTDs is filled, and the ATL PTD area will be processed. <b>0</b> — Indicates there is no PTD in this area. Therefore, processing of the ATL PTDs will completely be skipped.

### 8.3.7 ATL Done Timeout register

The bit description of the ATL Done Timeout register is given in [Table 44](#).

**Table 44. ATL Done Timeout register (address 0338h) bit description**

Bit	Symbol	Access	Value	Description
31 to 0	ATL_DONE_TIMEOUT[31:0]	R/W	0000 0000h	<b>ATL Done Timeout:</b> This register determines the ATL done time-out interrupt. This register defines the time-out in milliseconds after which the ISP1760 asserts the INT line, if enabled. It is applicable to ATL done PTDs only.

### 8.3.8 Memory register

The Memory register contains the base memory read address and the respective bank. This register needs to be set only before a first memory read cycle. Once written, the address will be latched for the bank and will be incremented for every read of that bank, until a new address for that bank is written to change the address pointer.

The bit description of the register is given in [Table 45](#).

**Table 45. Memory register (address 033Ch) bit allocation**

Bit	31	30	29	28	27	26	25	24
Symbol	reserved <sup>[1]</sup>							
Reset	0	0	0	0	0	0	0	0
Access	R/W	R/W	R/W	R/W	R/W	R/W	R/W	R/W
Bit	23	22	21	20	19	18	17	16
Symbol	reserved <sup>[1]</sup>						MEM_BANK_SEL[1:0]	
Reset	0	0	0	0	0	0	0	0
Access	R/W	R/W	R/W	R/W	R/W	R/W	R/W	R/W
Bit	15	14	13	12	11	10	9	8
Symbol	START_ADDR_MEM_READ[15:8]							
Reset	0	0	0	0	0	0	0	0
Access	R/W	R/W	R/W	R/W	R/W	R/W	R/W	R/W
Bit	7	6	5	4	3	2	1	0
Symbol	START_ADDR_MEM_READ[7:0]							
Reset	0	0	0	0	0	0	0	0
Access	R/W	R/W	R/W	R/W	R/W	R/W	R/W	R/W

[1] The reserved bits should always be written with the reset value.

**Table 46. Memory register (address 033Ch) bit description**

Bit	Symbol	Description
31 to 18	-	reserved
17 to 16	MEM_BANK_SEL[1:0]	<b>Memory Bank Select:</b> Up to four memory banks can be selected. For details on internal memory read description, see <a href="#">Section 7.3.1</a> . Applicable to PIO mode memory read or write data transfers only.
15 to 0	START_ADDR_MEM_READ [15:0]	<b>Start Address for Memory Read Cycles:</b> The start address for a series of memory read cycles at incremental addresses in a contiguous space. Applicable to PIO mode memory read data transfers only.

### 8.3.9 Force Hub Configuration register

The bit description of the register is given in [Table 47](#).

**Table 47. Force Hub Configuration register (address 0014h) bit allocation**

Bit	31	30	29	28	27	26	25	24
Symbol	reserved <sup>[1]</sup>							
Reset	0	0	0	0	0	0	0	0
Access	R	R	R	R	R	R	R	R
Bit	23	22	21	20	19	18	17	16
Symbol	reserved <sup>[1]</sup>							
Reset	0	0	0	0	0	0	0	0
Access	R	R	R	R	R	R	R	R
Bit	15	14	13	12	11	10	9	8
Symbol	reserved <sup>[1]</sup>							
Reset	0	0	0	0	0	0	0	0
Access	R	R	R	R	R	R	R	R
Bit	7	6	5	4	3	2	1	0
Symbol	reserved <sup>[1]</sup>							FORCE_CONF
Reset	0	0	0	0	0	0	0	0
Access	R	R	R	R	R	R	R	R/W

[1] The reserved bits should always be written with the reset value.

**Table 48. Force Hub Configuration register (address 0014h) bit description**

Bit	Symbol	Description
31 to 1	-	reserved
0	FORCE_CONF	<b>Force Configured:</b> On writing logic 1 to this bit, the hub will immediately go to the configured state. The hub state will remain unchanged on writing logic 0. When read, this field will always return 0.

### 8.3.10 Force Port Enable register

Write to bits 5 to 0 is enabled only when the FORCE\_CONF bit in the Force Hub Configuration register is set to logic 1. When bits 5 to 0 have values other than 00h, then the corresponding port will automatically transition to the enabled state. The value of bits 5 to 0 indicates the speed of the device attached to that port.

The bit description of the register is given in [Table 49](#).

**Table 49. Force Port Enable register (address 0018h) bit allocation**

Bit	31	30	29	28	27	26	25	24
Symbol	reserved <sup>[1]</sup>							
Reset	0	0	0	0	0	0	0	0
Access	R	R	R	R	R	R	R	R
Bit	23	22	21	20	19	18	17	16
Symbol	reserved <sup>[1]</sup>							
Reset	0	0	0	0	0	0	0	0
Access	R	R	R	R	R	R	R	R
Bit	15	14	13	12	11	10	9	8
Symbol	reserved <sup>[1]</sup>							
Reset	0	0	0	0	0	0	0	0
Access	R	R	R	R	R	R	R	R
Bit	7	6	5	4	3	2	1	0
Symbol	reserved <sup>[1]</sup>		PORT3_EN[1:0]		PORT2_EN[1:0]		PORT1_EN[1:0]	
Reset	0	0	0	0	0	0	0	0
Access	R	R	R/W	R/W	R/W	R/W	R/W	R/W

[1] The reserved bits should always be written with the reset value.

**Table 50. Force Port Enable register (address 0018h) bit description**

Bit	Symbol	Description
31 to 6	-	reserved
5 to 4	PORT3_EN[1:0]	<b>00</b> — Normal operation <b>01</b> — Port forced to the low-speed enabled state <b>10</b> — Port forced to the full-speed enabled state <b>11</b> — Port forced to the high-speed enabled state
3 to 2	PORT2_EN[1:0]	<b>00</b> — Normal operation <b>01</b> — Port forced to the low-speed enabled state <b>10</b> — Port forced to the full-speed enabled state <b>11</b> — Port forced to the high-speed enabled state
1 to 0	PORT1_EN[1:0]	<b>00</b> — Normal operation <b>01</b> — Port forced to the low-speed enabled state <b>10</b> — Port forced to the full-speed enabled state <b>11</b> — Port forced to the high-speed enabled state

### 8.3.11 Edge Interrupt Count register

[Table 51](#) shows the bit allocation of the register.

**Table 51. Edge Interrupt Count register (address 0340h) bit allocation**

Bit	31	30	29	28	27	26	25	24
Symbol	MIN_WIDTH[7:0]							
Reset	0	0	0	0	0	0	0	0
Access	R/W	R/W	R/W	R/W	R/W	R/W	R/W	R/W
Bit	23	22	21	20	19	18	17	16
Symbol	reserved <sup>[1]</sup>							
Reset	0	0	0	0	0	0	0	0
Access	R/W	R/W	R/W	R/W	R/W	R/W	R/W	R/W
Bit	15	14	13	12	11	10	9	8
Symbol	NO_OF_CLK[15:8]							
Reset	0	0	0	0	0	0	0	0
Access	R/W	R/W	R/W	R/W	R/W	R/W	R/W	R/W
Bit	7	6	5	4	3	2	1	0
Symbol	NO_OF_CLK[7:0]							
Reset	0	0	0	0	1	1	1	1
Access	R/W	R/W	R/W	R/W	R/W	R/W	R/W	R/W

[1] The reserved bits should always be written with the reset value.

**Table 52. Edge Interrupt Count register (address 0340h) bit description**

Bit	Symbol	Description
31 to 24	MIN_WIDTH[7:0]	<b>Minimum Width:</b> Indicates the minimum width between two edge interrupts in $\mu$ SOFs (1 $\mu$ SOF = 125 $\mu$ s). This is not valid for level interrupts. A count of zero means that interrupts occur as and when an event occurs.
23 to 16	-	reserved
15 to 0	NO_OF_CLK[15:0]	<b>Number of Clocks:</b> Count in number of clocks that the edge interrupt must be kept asserted on the interface. The default value of these bits is 000Fh. 16 clocks of 30 MHz is approximately 500 ns, which is the default IRQ pulse width.

### 8.3.12 DMA Start Address register

This register defines the start address select for the DMA read and write operations. See [Table 53](#) for the bit allocation.

**Table 53. DMA Start Address register (address 0344h) bit allocation**

Bit	31	30	29	28	27	26	25	24
Symbol	reserved <sup>[1]</sup>							
Reset	0	0	0	0	0	0	0	0
Access	W	W	W	W	W	W	W	W
Bit	23	22	21	20	19	18	17	16
Symbol	reserved <sup>[1]</sup>							
Reset	0	0	0	0	0	0	0	0
Access	W	W	W	W	W	W	W	W



Bit	15	14	13	12	11	10	9	8
Symbol	START_ADDR_DMA[15:8]							
Reset	0	0	0	0	0	0	0	0
Access	W	W	W	W	W	W	W	W
Bit	7	6	5	4	3	2	1	0
Symbol	START_ADDR_DMA[7:0]							
Reset	0	0	0	0	0	0	0	0
Access	W	W	W	W	W	W	W	W

[1] The reserved bits should always be written with the reset value.

**Table 54. DMA Start Address register (address 0344h) bit description**

Bit	Symbol	Description
31 to 16	-	reserved
15 to 0	START_ADDR_DMA[15:0]	<b>Start Address for DMA:</b> The start address for DMA read or write cycles.

### 8.3.13 Power Down Control register

This register is used to turn off power to the internal blocks of the ISP1760 to obtain maximum power savings. [Table 55](#) shows the bit allocation of the register.

**Table 55. Power Down Control register (address 0354h) bit allocation**

Bit	31	30	29	28	27	26	25	24
Symbol	CLK_OFF_COUNTER[15:8]							
Reset	0	0	0	0	0	0	1	1
Access	R/W	R/W	R/W	R/W	R/W	R/W	R/W	R/W
Bit	23	22	21	20	19	18	17	16
Symbol	CLK_OFF_COUNTER[7:0]							
Reset	1	1	1	0	1	0	0	0
Access	R/W	R/W	R/W	R/W	R/W	R/W	R/W	R/W
Bit	15	14	13	12	11	10	9	8
Symbol	reserved <sup>[1]</sup>			PORT3_PD	PORT2_PD	VBATDET_PWR	reserved <sup>[1]</sup>	
Reset	0	0	0	1	1	0	1	1
Access	R/W	R/W	R/W	R/W	R/W	R/W	R/W	R/W
Bit	7	6	5	4	3	2	1	0
Symbol	reserved <sup>[1]</sup>		BIASEN	VREG_ON	OC3_PWR	OC2_PWR	OC1_PWR	HC_CLK_EN
Reset	1	0	1	0	0	0	0	0
Access	R/W	R/W	R/W	R/W	R/W	R/W	R/W	R/W

[1] The reserved bits should always be written with the reset value.

**Table 56. Power Down Control register (address 0354h) bit description**

Bit <sup>[1]</sup>	Symbol	Description
31 to 16	CLK_OFF_COUNTER [15:0]	<p><b>Clock Off Counter:</b> Determines the wake-up status duration after any wake-up event before the ISP1760 goes back into suspend mode. This time-out is applicable only if, during the given interval, the host controller is not programmed back to the normal functionality.</p> <p><b>03E8h</b> — The default value. It determines the default wake-up interval of 10 ms. A value of zero implies that the host controller never wakes up on any of the events. This may be useful when using the ISP1760 as a peripheral to save power by permanently programming the host controller in suspend.</p> <p><b>FFFFh</b> — The maximum value. It determines a maximum wake-up time of 500 ms.</p> <p>The setting of this register is based on the 100 kHz ± 40 % LazyClock frequency. It is a multiple of 10 μs period.</p> <p><b>Remark:</b> In 16-bit mode, the default value is 17E8h. A write operation to these bits with any value fixes the clock off counter at 1400h. This value is equivalent to a fixed wake-up time of 50 ms.</p>
15 to 13	-	reserved
12	PORT3_PD	<p><b>Port 3 Pull-Down:</b> Controls port 3 pull-down resistors.</p> <p><b>0</b> — Port 3 internal pull-down resistors are not connected.</p> <p><b>1</b> — Port 3 internal pull-down resistors are connected.</p>
11	PORT2_PD	<p><b>Port 2 Pull-Down:</b> Controls port 2 pull-down resistors.</p> <p><b>0</b> — Port 2 internal pull-down resistors are not connected.</p> <p><b>1</b> — Port 2 internal pull-down resistors are connected.</p>
10	VBATDET_PWR	<p><b>V<sub>BAT</sub> Detector Powered:</b> Controls the power to the V<sub>BAT</sub> detector.</p> <p><b>0</b> — V<sub>BAT</sub> detector is powered or enabled in suspend.</p> <p><b>1</b> — V<sub>BAT</sub> detector is not powered or disabled in suspend.</p>
9 to 6	-	reserved; write reset value
5	BIASEN	<p><b>Bias Circuits Powered:</b> Controls the power to internal bias circuits.</p> <p><b>0</b> — Internal bias circuits are not powered in suspend.</p> <p><b>1</b> — Internal bias circuits are powered in suspend.</p>
4	VREG_ON	<p><b>V<sub>REG</sub> Powered:</b> Enables or disables the internal 3.3 V and 1.8 V regulators when the ISP1760 is in suspend.</p> <p><b>0</b> — Internal regulators are normally powered in suspend.</p> <p><b>1</b> — Internal regulators switch to low power mode (in suspend mode).</p>
3	OC3_PWR	<p><b>OC3_N Powered:</b> Controls the powering of the overcurrent detection circuitry for port 3.</p> <p><b>0</b> — Overcurrent detection is powered on or enabled during suspend.</p> <p><b>1</b> — Overcurrent detection is powered off or disabled during suspend.</p> <p>This may be useful when connecting a faulty device while the system is in standby.</p>

**Table 56. Power Down Control register (address 0354h) bit description ...continued**

Bit <sup>[1]</sup>	Symbol	Description
2	OC2_PWR	<p><b>OC2_N Powered:</b> Controls the powering of the overcurrent detection circuitry for port 2.</p> <p><b>0</b> — Overcurrent detection is powered-on or enabled during suspend.</p> <p><b>1</b> — Overcurrent detection is powered-off or disabled during suspend.</p> <p>This may be useful when connecting a faulty device while the system is in standby.</p>
1	OC1_PWR	<p><b>OC1_N Powered:</b> Controls the powering of the overcurrent detection circuitry for port 1.</p> <p><b>0</b> — Overcurrent detection is powered-on or enabled during suspend.</p> <p><b>1</b> — Overcurrent detection is powered-off or disabled during suspend.</p> <p>This may be useful when connecting a faulty device while the system is in standby.</p>
0	HC_CLK_EN	<p><b>Host Controller Clock Enabled:</b> Controls internal clocks during suspend.</p> <p><b>0</b> — Clocks are disabled during suspend. This is the default value. Only the LazyClock of 100 kHz <math>\pm</math> 40 % will be left running in suspend if this bit is logic 0. If clocks are stopped during suspend, CLKREADY IRQ will be generated when all clocks are running stable.</p> <p><b>1</b> — All clocks are enabled even in suspend.</p>

[1] For a 32-bit operation, the default wake-up counter value is 10  $\mu$ s. For a 16-bit operation, the wake-up counter value is 50 ms. In the 16-bit operation, read and write back the same value on initialization.

### 8.3.14 Port 1 Control register

The values read from the lower 16 bits and the upper 16 bits of this register are always the same. [Table 57](#) shows the bit allocation of the register.

**Table 57. Port 1 Control register (address 0374h) bit allocation**

Bit	31	30	29	28	27	26	25	24
Symbol	reserved							
Reset	0	0	0	0	0	0	0	0
Access	R/W	R/W	R/W	R/W	R/W	R/W	R/W	R/W
Bit	23	22	21	20	19	18	17	16
Symbol	PORT1_INIT2	reserved						
Reset	1	0	0	0	0	1	1	0
Access	R/W	R/W	R/W	R/W	R/W	R/W	R/W	R/W
Bit	15	14	13	12	11	10	9	8
Symbol	reserved							
Reset	0	0	0	0	0	0	0	0
Access	R/W	R/W	R/W	R/W	R/W	R/W	R/W	R/W
Bit	7	6	5	4	3	2	1	0
Symbol	PORT1_INIT1	reserved		PORT1_POWER[1:0]		reserved		
Reset	0	0	0	1	0	1	1	0
Access	R/W	R/W	R/W	R/W	R/W	R/W	R/W	R/W

**Table 58. Port 1 Control register (address 0374h) bit description**

Bit <sup>[1]</sup>	Symbol	Description
31 to 24	-	reserved; write reset value
23	PORT1_INIT2	<b>Port 1 Initialization 2:</b> Write logic 1 at the ISP1760 initialization. It will clear both this bit and bit 7. Affects only port 1.
22 to 8	-	reserved
7	PORT1_INIT1	<b>Port 1 Initialization 1:</b> Must be reset to logic 0 at power-up initialization for correct operation of port 1. Correct host controller functionality is not ensured if set to logic 1 (affects only port 1). To clear this bit, logic 1 must be written to bit 23 during the ISP1760 initialization. This is not required for the normal functionality of port 2 and port 3.
6 to 5	-	reserved
4 to 3	PORT1_POWER [1:0]	<b>Port 1 Power:</b> Set these bits to 11b. These bits must be set to enable port 1 power.
2 to 0	-	reserved; write reset value

[1] For correct port 1 initialization, write 0080 0018h to this register after power-on.

## 8.4 Interrupt registers

### 8.4.1 Interrupt register

The bits of this register indicate the interrupt source, defining the events that determined the INT generation. Clearing the bits that were set because of the events listed is done by writing back logic 1 to the respective position. All bits must be reset before enabling new interrupt events. These bits will be set, regardless of the setting of bit GLOBAL\_INTR\_EN in the HW Mode Control register. [Table 59](#) shows the bit allocation of the Interrupt register.

**Table 59. Interrupt register (address 0310h) bit allocation**

Bit	31	30	29	28	27	26	25	24
Symbol	reserved <sup>[1]</sup>							
Reset	0	0	0	0	0	0	0	0
Access	R/W	R/W	R/W	R/W	R/W	R/W	R/W	R/W
Bit	23	22	21	20	19	18	17	16
Symbol	reserved <sup>[1]</sup>							
Reset	0	0	0	0	0	0	0	0
Access	R/W	R/W	R/W	R/W	R/W	R/W	R/W	R/W
Bit	15	14	13	12	11	10	9	8
Symbol	reserved <sup>[1]</sup>						ISO_IRQ	ATL_IRQ
Reset	0	0	0	0	0	0	0	0
Access	R/W	R/W	R/W	R/W	R/W	R/W	R/W	R/W
Bit	7	6	5	4	3	2	1	0
Symbol	INT_IRQ	CLK_READY	HC_SUSP	reserved <sup>[1]</sup>	DMAEOT_INT	reserved <sup>[1]</sup>	SOFITLINT	reserved <sup>[1]</sup>
Reset	0	0	0	0	0	0	0	0
Access	R/W	R/W	R/W	R/W	R/W	R/W	R/W	R/W

[1] The reserved bits should always be written with the reset value.

**Table 60. Interrupt register (address 0310h) bit description**

Bit	Symbol	Description
31 to 10	-	reserved; write reset value
9	ISO_IRQ	<p><b>ISO IRQ:</b> Indicates that an ISO PTD was completed, or the PTDs corresponding to the bits set in the ISO IRQ Mask AND or ISO IRQ Mask OR register bits combination were completed. The IRQ line will be asserted if the respective enable bit in the HCInterruptEnable register is set.</p> <p><b>0</b> — No ISO PTD event occurred.  <b>1</b> — ISO PTD event occurred.</p> <p>For details, see <a href="#">Section 7.4</a>.</p>
8	ATL_IRQ	<p><b>ATL IRQ:</b> Indicates that an ATL PTD was completed, or the PTDs corresponding to the bits set in the ATL IRQ Mask AND or ATL IRQ Mask OR register bits combination were completed. The IRQ line will be asserted if the respective enable bit in the HCInterruptEnable register is set.</p> <p><b>0</b> — No ATL PTD event occurred.  <b>1</b> — ATL PTD event occurred.</p> <p>For details, see <a href="#">Section 7.4</a>.</p>
7	INT_IRQ	<p><b>INT IRQ:</b> Indicates that an INT PTD was completed, or the PTDs corresponding to the bits set in the INT IRQ Mask AND or INT IRQ Mask OR register bits combination were completed. The IRQ line will be asserted if the respective enable bit in the HCInterruptEnable register is set.</p> <p><b>0</b> — No INT PTD event occurred.  <b>1</b> — INT PTD event occurred.</p> <p>For details, see <a href="#">Section 7.4</a>.</p>
6	CLK READY	<p><b>Clock Ready:</b> Indicates that internal clock signals are running stable. The IRQ line will be asserted if the respective enable bit in the HCInterruptEnable register is set.</p> <p><b>0</b> — No CLKREADY event has occurred.  <b>1</b> — CLKREADY event occurred.</p>
5	HC_SUSP	<p><b>Host Controller Suspend:</b> Indicates that the host controller has entered suspend mode. The IRQ line will be asserted if the respective enable bit in the HCInterruptEnable register is set.</p> <p><b>0</b> — The host controller did not enter suspend mode.  <b>1</b> — The host controller entered suspend mode.</p> <p>If the ISR accesses the ISP1760, it will wake up for the time specified in bits 31 to 16 of the Power Down Control register.</p>
4	-	reserved; write reset value
3	DMAEOT INT	<p><b>DMA EOT Interrupt:</b> Indicates the DMA transfer completion. The IRQ line will be asserted if the respective enable bit in the HCInterruptEnable register is set.</p> <p><b>0</b> — No DMA transfer is completed.  <b>1</b> — DMA transfer is complete.</p>

**Table 60. Interrupt register (address 0310h) bit description ...continued**

Bit	Symbol	Description
2	-	reserved; write reset value; value is zero just after reset and changes to one after a short while
1	SOFITL INT	<b>SOT ITL Interrupt:</b> The IRQ line will be asserted if the respective enable bit in the HCInterruptEnable register is set. <b>0</b> — No SOF event has occurred. <b>1</b> — An SOF event has occurred.
0	-	reserved; write reset value; value is zero just after reset and changes to one after a short while

### 8.4.2 Interrupt Enable register

This register allows enabling or disabling of the IRQ generation because of various events as described in [Table 61](#).

**Table 61. Interrupt Enable register (address 0314h) bit allocation**

Bit	31	30	29	28	27	26	25	24
Symbol	reserved <sup>[1]</sup>							
Reset	0	0	0	0	0	0	0	0
Access	R/W	R/W	R/W	R/W	R/W	R/W	R/W	R/W
Bit	23	22	21	20	19	18	17	16
Symbol	reserved <sup>[1]</sup>							
Reset	0	0	0	0	0	0	0	0
Access	R/W	R/W	R/W	R/W	R/W	R/W	R/W	R/W
Bit	15	14	13	12	11	10	9	8
Symbol	reserved <sup>[1]</sup>						ISO_IRQ_E	ATL_IRQ_E
Reset	0	0	0	0	0	0	0	0
Access	R/W	R/W	R/W	R/W	R/W	R/W	R/W	R/W
Bit	7	6	5	4	3	2	1	0
Symbol	INT_IRQ_E	CLKREADY_E	HCSUSP_E	reserved <sup>[1]</sup>	DMAEOT_INT_E	reserved <sup>[1]</sup>	SOFITLINT_E	reserved <sup>[1]</sup>
Reset	0	0	0	0	0	0	0	0
Access	R/W	R/W	R/W	R/W	R/W	R/W	R/W	R/W

[1] The reserved bits should always be written with the reset value.

**Table 62. Interrupt Enable register (address 0314h) bit description**

Bit	Symbol	Description
31 to 10	-	reserved; write logic 0
9	ISO_IRQ_E	<p><b>ISO IRQ Enable:</b> Controls the IRQ assertion when one or more ISO PTDs matching the ISO IRQ Mask AND or ISO IRQ Mask OR register bits combination are completed.</p> <p><b>0</b> — No IRQ will be asserted when ISO PTDs are completed.</p> <p><b>1</b> — IRQ will be asserted.</p> <p>For details, see <a href="#">Section 7.4</a>.</p>
8	ATL_IRQ_E	<p><b>ATL IRQ Enable:</b> Controls the IRQ assertion when one or more ATL PTDs matching the ATL IRQ Mask AND or ATL IRQ Mask OR register bits combination are completed.</p> <p><b>0</b> — No IRQ will be asserted when ATL PTDs are completed.</p> <p><b>1</b> — IRQ will be asserted.</p> <p>For details, see <a href="#">Section 7.4</a>.</p>
7	INT_IRQ_E	<p><b>INT IRQ Enable:</b> Controls the IRQ assertion when one or more INT PTDs matching the INT IRQ Mask AND or INT IRQ Mask OR register bits combination are completed.</p> <p><b>0</b> — No IRQ will be asserted when INT PTDs are completed.</p> <p><b>1</b> — IRQ will be asserted.</p> <p>For details, see <a href="#">Section 7.4</a>.</p>
6	CLKREADY_E	<p><b>Clock Ready Enable:</b> Enables the IRQ assertion when internal clock signals are running stable. Useful after wake-up.</p> <p><b>0</b> — No IRQ will be generated after a CLKREADY_E event.</p> <p><b>1</b> — IRQ will be generated after a CLKREADY_E event.</p>
5	HCSUSP_E	<p><b>Host Controller Suspend Enable:</b> Enables the IRQ generation when the host controller enters suspend mode.</p> <p><b>0</b> — No IRQ will be generated when the host controller enters suspend mode.</p> <p><b>1</b> — IRQ will be generated when the host controller enters suspend mode.</p>
4	-	reserved; write logic 0
3	DMAEOTINT_E	<p><b>DMA EOT Interrupt Enable:</b> Controls assertion of IRQ on the DMA transfer completion.</p> <p><b>0</b> — No IRQ will be generated when a DMA transfer is completed.</p> <p><b>1</b> — IRQ will be asserted when a DMA transfer is completed.</p>
2	-	reserved; must be written with logic 0
1	SOFITLINT_E	<p><b>SOT ITL Interrupt Enable:</b> Controls the IRQ generation at every SOF occurrence.</p> <p><b>0</b> — No IRQ will be generated on an SOF occurrence.</p> <p><b>1</b> — IRQ will be asserted at every SOF.</p>
0	-	reserved; must be written with logic 0

### 8.4.3 ISO IRQ Mask OR register

Each bit of this register corresponds to one of the 32 ISO PTDs defined, and is a hardware IRQ mask for each PTD done map. See [Table 63](#) for bit description. For details, see [Section 7.4](#).

**Table 63. ISO IRQ Mask OR register (address 0318h) bit description**

Bit	Symbol	Access	Value	Description
31 to 0	ISO_IRQ_MASK_OR[31:0]	R/W	0000 0000h	<b>ISO IRQ Mask OR:</b> Represents a direct map for ISO PTDs 31 to 0. <b>0</b> — No OR condition defined between ISO PTDs. <b>1</b> — The bits corresponding to certain PTDs are set to logic 1 to define a certain OR condition.

### 8.4.4 INT IRQ Mask OR register

Each bit of this register (see [Table 64](#)) corresponds to one of the 32 INT PTDs defined, and is a hardware IRQ mask for each PTD done map. For details, see [Section 7.4](#).

**Table 64. INT IRQ Mask OR register (address 031Ch) bit description**

Bit	Symbol	Access	Value	Description
31 to 0	INT_IRQ_MASK_OR[31:0]	R/W	0000 0000h	<b>INT IRQ Mask OR:</b> Represents a direct map for INT PTDs 31 to 0. <b>0</b> — No OR condition defined between INT PTDs 31 to 0. <b>1</b> — The bits corresponding to certain PTDs are set to logic 1 to define a certain OR condition.

### 8.4.5 ATL IRQ Mask OR register

Each bit of this register corresponds to one of the 32 ATL PTDs defined, and is a hardware IRQ mask for each PTD done map. See [Table 65](#) for bit description. For details, see [Section 7.4](#).

**Table 65. ATL IRQ Mask OR register (address 0320h) bit description**

Bit	Symbol	Access	Value	Description
31 to 0	ATL_IRQ_MASK_OR[31:0]	R/W	0000 0000h	<b>ATL IRQ Mask OR:</b> Represents a direct map for ATL PTDs 31 to 0. <b>0</b> — No OR condition defined between the ATL PTDs. <b>1</b> — The bits corresponding to certain PTDs are set to logic 1 to define a certain OR condition.

### 8.4.6 ISO IRQ Mask AND register

Each bit of this register corresponds to one of the 32 ISO PTDs defined, and is a hardware IRQ mask for each PTD done map. For details, see [Section 7.4](#).

[Table 66](#) provides the bit description of the register.

**Table 66. ISO IRQ Mask AND register (address 0324h) bit description**

Bit	Symbol	Access	Value	Description
31 to 0	ISO_IRQ_MASK_AND[31:0]	R/W	0000 0000h	<b>ISO IRQ Mask AND:</b> Represents a direct map for ISO PTDs 31 to 0. <b>0</b> — No AND condition defined between ISO PTDs. <b>1</b> — The bits corresponding to certain PTDs are set to logic 1 to define a certain AND condition between the 32 INT PTDs.

### 8.4.7 INT IRQ Mask AND register

Each bit of this register (see [Table 67](#)) corresponds to one of the 32 INT PTDs defined, and is a hardware IRQ mask for each PTD done map. For details, see [Section 7.4](#).



**Table 67. INT IRQ Mask AND register (address 0328h) bit description**

Bit	Symbol	Access	Value	Description
31 to 0	INT_IRQ_MASK_AND[31:0]	R/W	0000 0000h	<p><b>INT IRQ Mask AND:</b> Represents a direct map for INT PTDs 31 to 0.</p> <p><b>0</b> — No OR condition defined between INT PTDs.</p> <p><b>1</b> — The bits corresponding to certain PTDs are set to logic 1 to define a certain AND condition between the 32 INT PTDs.</p>

### 8.4.8 ATL IRQ Mask AND register

Each bit of this register corresponds to one of the 32 ATL PTDs defined, and is a hardware IRQ mask for each PTD done map. For details, see [Section 7.4](#).

[Table 68](#) shows the bit description of the register.

**Table 68. ATL IRQ Mask AND register (address 032Ch) bit description**

Bit	Symbol	Access	Value	Description
31 to 0	ATL_IRQ_MASK_AND[31:0]	R/W	0000 0000h	<p><b>ATL IRQ Mask AND:</b> Represents a direct map for ATL PTDs 31 to 0.</p> <p><b>0</b> — No OR condition defined between ATL PTDs.</p> <p><b>1</b> — The bits corresponding to certain PTDs are set to logic 1 to define a certain AND condition between the 32 ATL PTDs.</p>

## 9. Proprietary Transfer Descriptor (PTD)

The standard EHCI data structures as described in [Ref. 2 “Enhanced Host Controller Interface Specification for Universal Serial Bus Rev. 1.0”](#) are optimized for the bus master operation that is managed by the hardware state machine.

The PTD structures of the ISP1760 are translations of the EHCI data structures that are optimized for the ISP1760. It, however, still follows the basic EHCI architecture. This optimized form of EHCI data structures is necessary because the ISP1760 is a slave host controller and has no bus master capability.

EHCI manages schedules in two lists: periodic and asynchronous. The data structures are designed to provide the maximum flexibility required by USB, minimize memory traffic, and reduce hardware and software complexity. The ISP1760 controller executes transactions for devices by using a simple shared-memory schedule. This schedule consists of data structures organized into three lists.

**qISO** — Isochronous transfer

**qINTL** — Interrupt transfer

**qATL** — Asynchronous transfer; for the control and bulk transfers

The system software maintains two lists for the host controller: periodic and asynchronous.

The ISP1760 has a maximum of 32 ISO, 32 INTL and 32 ATL PTDs. These PTDs are used as channels to transfer data from the shared memory to the USB bus. These channels are allocated and de-allocated on receiving the transfer from the core USB driver.

Multiple transfers are scheduled to the shared memory for various endpoints by traversing the next link pointer provided by endpoint data structures, until it reaches the end of the endpoint list. There are three endpoint lists: one for ISO endpoints, and the other for INTL and ATL endpoints. If the schedule is enabled, the host controller executes the ISO schedule, followed by the INTL schedule, and then the ATL schedule.

These lists are traversed and scheduled by the software according to the EHCI traversal rule. The host controller executes the scheduled ISO, INTL and ATL PTDs. The completion of a transfer is indicated to the software by the interrupt that can be grouped under various PTDs by using the AND or OR registers that are available for each schedule type: ISO, INTL and ATL. These registers are simple logic registers to decide the completion status of group and individual PTDs. When the logical conditions of the Done bit is true in the shared memory, it means that PTD has completed.

There are four types of interrupts in the ISP1760: ISO, INTL, ATL and SOF. The latency can be programmed in multiples of  $\mu\text{SOF}$  (125  $\mu\text{s}$ ).

The NextPTD pointer is a feature that allows the ISP1760 to jump unused and skip PTDs. This will improve the PTD transversal latency time. The NextPTD pointer is not meant for same or single endpoint. The NextPTD works only in forward direction.

The NextPTD traversal rules defined by the ISP1760 hardware are:

1. Start the PTD memory vertical traversal, considering the skip and LastPTD information, as follows.
2. If the current PTD is active and not done, perform the transaction.
3. Follow the NextPTD pointer as specified in bits 4 to 0 of DW4.
4. If combined with LastPTD, the LastPTD setting must be at a higher address than the NextPTD specified. So both are set in a logical manner.
5. If combined with skip, the skip must not be set (logically) on the same position corresponding to NextPTD, pointed by the NextPTD pointer.
6. If PTD is set for skip, it will be neglected and the next vertical PTD will be considered.
7. If the skipped PTD already has a setting including a NextPTD pointer that will not be taken into consideration, the behavior will be just as described in the preceding step.

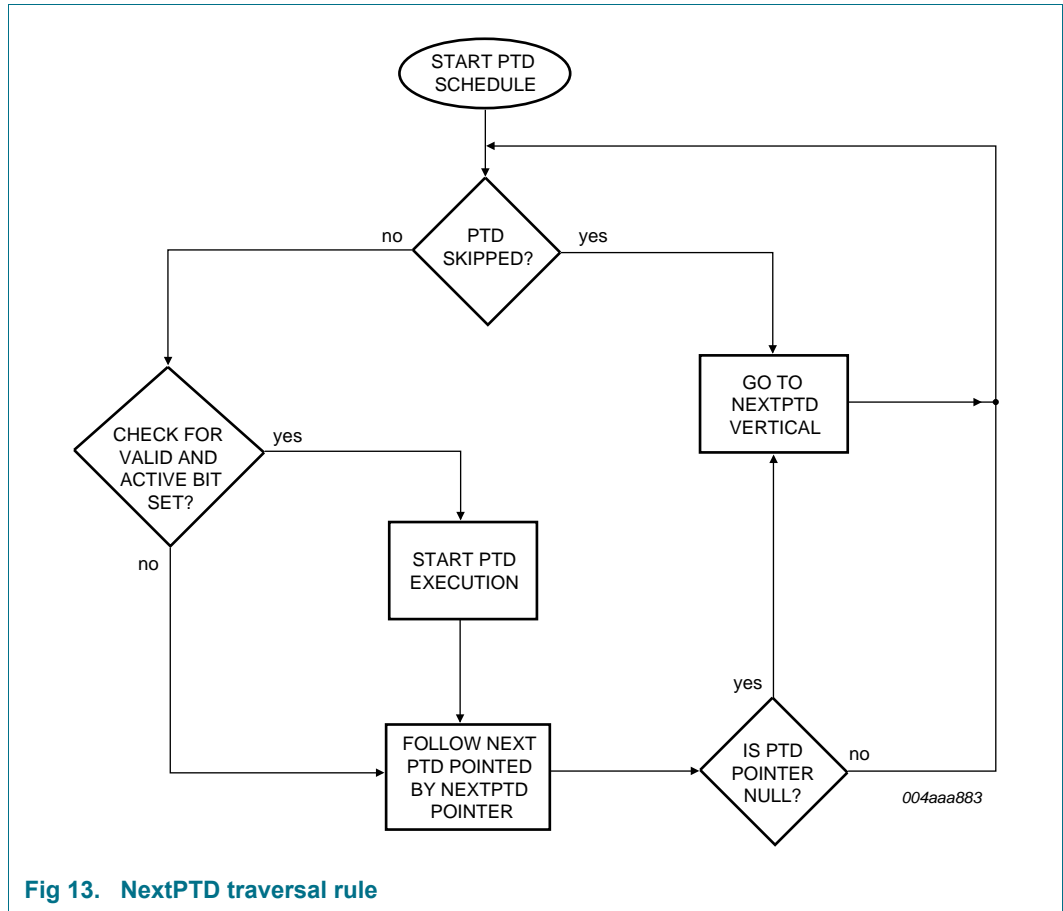

Fig 13. NextPTD traversal rule

## 9.1 High-speed bulk IN and OUT

[Table 69](#) shows the bit allocation of the high-speed bulk IN and OUT, bulk Transfer Descriptor.

**Table 69. High-speed bulk IN and OUT: bit allocation**

Bit	63	62	61	60	59	58	57	56	55	54	53	52	51	50	49	48	47	46	45	44	43	42	41	40	39	38	37	36	35	34	33	32
<b>DW7</b>	reserved																															
<b>DW5</b>	reserved																															
<b>DW3</b>	A	H	B	X	[1]	P	DT	Cerr [1:0]	NakCnt[3:0]			reserved			NrBytesTransferred[14:0] (32 kB – 1 B for high-speed)																	
<b>DW1</b>	reserved													S	EP Type [1:0]	Token [1:0]	DeviceAddress[6:0]						EndPt[3:1]									
Bit	31	30	29	28	27	26	25	24	23	22	21	20	19	18	17	16	15	14	13	12	11	10	9	8	7	6	5	4	3	2	1	0
<b>DW6</b>	reserved																															
<b>DW4</b>	reserved																								J	NextPTDPointer[4:0]						
<b>DW2</b>	reserved		RL[3:0]			[1]	DataStartAddress[15:0]														reserved											
<b>DW0</b>	[2]	Mult [1:0]		MaxPacketLength[10:0]									NrBytesToTransfer[14:0]														[1]	V				

[1] Reserved.

[2] EndPt[0].

**Table 70. High-speed bulk IN and OUT: bit description**

Bit	Symbol	Access	Value	Description
<b>DW7</b>				
63 to 32	reserved	-	-	-
<b>DW6</b>				
31 to 0	reserved	-	-	-
<b>DW5</b>				
63 to 32	reserved	-	-	-
<b>DW4</b>				
31 to 6	reserved	-	0	not applicable
5	J	<b>SW</b> — writes	-	<b>Jump:</b> <b>0</b> — To increment the PTD pointer. <b>1</b> — To enable the next PTD branching.
4 to 0	NextPTDPointer [4:0]	<b>SW</b> — writes	-	<b>Next PTD Counter:</b> Next PTD branching assigned by the PTD pointer.
<b>DW3</b>				
63	A	<b>SW</b> — sets <b>HW</b> — resets	-	<b>Active:</b> Write the same value as that in V.
62	H	<b>HW</b> — writes	-	<b>Halt:</b> This bit corresponds to the Halt bit of the Status field of TD.
61	B	<b>HW</b> — writes	-	<b>Babble:</b> This bit corresponds to the Babble Detected bit in the Status field of iTD, siTD or TD. <b>1</b> — When babbling is detected, A and V are set to 0.
60	X	<b>HW</b> — writes	-	<b>Error:</b> This bit corresponds to the Transaction Error bit in the Status field of iTD, siTD or TD (Exec_Trans, the signal name is xacterr). <b>0</b> — No PID error. <b>1</b> — If there are PID errors, this bit is set active. The A and V bits are also set to inactive. This transaction is retried three times.
		<b>SW</b> — writes	-	<b>0</b> — Before scheduling.
59	reserved	-	-	-
58	P	<b>SW</b> — writes <b>HW</b> — updates	-	<b>Ping:</b> For high-speed transactions, this bit corresponds to the Ping state bit in the Status field of a TD. <b>0</b> — Ping is not set. <b>1</b> — Ping is set. For the first time, software sets the Ping bit to 0. For the successive asynchronous TD, software sets the bit in asynchronous TD based on the state of the bit for the previous asynchronous TD of the same transfer, that is: <ul style="list-style-type: none"> <li>The current asynchronous TD is completed with the Ping bit set.</li> <li>The next asynchronous TD will have its Ping bit set by the software.</li> </ul>
57	DT	<b>HW</b> — updates <b>SW</b> — writes	-	<b>Data Toggle:</b> This bit is filled by software to start a PTD. If NrBytesToTransfer[14:0] is not complete, software needs to read this value and then write back the same value to continue.

**Table 70. High-speed bulk IN and OUT: bit description ...continued**

Bit	Symbol	Access	Value	Description
56 to 55	Cerr[1:0]	<b>HW</b> — writes <b>SW</b> — writes	-	<b>Error Counter:</b> This field corresponds to the Cerr[1:0] field in TD. The default value of this field is zero for isochronous transactions. <b>00</b> — The transaction will not retry. <b>11</b> — The transaction will retry three times. Hardware will decrement these values.
54 to 51	NakCnt[3:0]	<b>HW</b> — writes <b>SW</b> — writes	-	<b>NAK Counter:</b> This field corresponds to the NakCnt field in TD. Software writes for the initial PTD launch. The V bit is reset if NakCnt decrements to zero and RL is a nonzero value. It reloads from RL if transaction is ACK-ed.
50 to 47	reserved	-	-	-
46 to 32	NrBytes Transferred [14:0]	<b>HW</b> — writes <b>SW</b> — writes 0000	-	<b>Number of Bytes Transferred:</b> This field indicates the number of bytes sent or received for this transaction. If Mult[1:0] is greater than one, it is possible to store intermediate results in this field.
<b>DW2</b>				
31 to 29	reserved	-	-	Set to 0 for asynchronous TD.
28 to 25	RL[3:0]	<b>SW</b> — writes	-	<b>Reload:</b> If RL is set to 0h, hardware ignores the NakCnt value. RL and NakCnt are set to the same value before a transaction.
24	reserved	-	-	Always 0 for asynchronous TD.
23 to 8	DataStart Address[15:0]	<b>SW</b> — writes	-	<b>Data Start Address:</b> This is the start address for data that will be sent or received on or from the USB bus. This is the internal memory address and not the direct CPU address. RAM address = (CPU address – 400h) / 8
7 to 0	reserved	-	-	-
<b>DW1</b>				
63 to 47	reserved	-	-	Always 0 for asynchronous TD.
46	S	<b>SW</b> — writes	-	This bit indicates whether a split transaction has to be executed: <b>0</b> — High-speed transaction <b>1</b> — Split transaction
45 to 44	EPTType[1:0]	<b>SW</b> — writes	-	Transaction type: <b>00</b> — Control <b>10</b> — Bulk
43 to 42	Token[1:0]	<b>SW</b> — writes	-	<b>Token:</b> Identifies the token Packet Identifier (PID) for this transaction: <b>00</b> — OUT <b>01</b> — IN <b>10</b> — SETUP <b>11</b> — PING (written by hardware only)
41 to 35	DeviceAddress [6:0]	<b>SW</b> — writes	-	<b>Device Address:</b> This is the USB address of the function containing the endpoint that is referred to by this buffer.
34 to 32	EndPt[3:1]	<b>SW</b> — writes	-	<b>Endpoint:</b> This is the USB address of the endpoint within the function.

**Table 70. High-speed bulk IN and OUT: bit description ...continued**

Bit	Symbol	Access	Value	Description
<b>DW0</b>				
31	EndPt[0]	<b>SW</b> — writes	-	<b>Endpoint:</b> This is the USB address of the endpoint within the function.
30 to 29	Mult[1:0]	<b>SW</b> — writes	-	<b>Multiplier:</b> This field is a multiplier used by the host controller as the number of successive packets the host controller may submit to the endpoint in the current execution. Set this field to 01b. You can also set it to 11b and 10b depending on your application. 00b is undefined.
28 to 18	MaxPacket Length[10:0]	<b>SW</b> — writes	-	<b>Maximum Packet Length:</b> This field indicates the maximum number of bytes that can be sent to or received from an endpoint in a single data packet. The maximum packet size for a bulk transfer is 512 bytes. The maximum packet size for the isochronous transfer is also variable at any whole number.
17 to 3	NrBytesTo Transfer[14:0]	<b>SW</b> — writes	-	<b>Number of Bytes to Transfer:</b> This field indicates the number of bytes that can be transferred by this data structure. It is used to indicate the depth of the DATA field (32 kB – 1 B).
2 to 1	reserved	-	-	-
0	V	<b>SW</b> — sets <b>HW</b> — resets	-	<b>Valid:</b> <b>0</b> — This bit is deactivated when the entire PTD is executed, or when a fatal error is encountered. <b>1</b> — Software updates to one when there is payload to be sent or received. The current PTD is active.

## 9.2 High-speed isochronous IN and OUT

[Table 71](#) shows the bit allocation of the high-speed isochronous IN and OUT, isochronous Transfer Descriptor (iTID).

**Table 71. High-speed isochronous IN and OUT: bit allocation**

Bit	63	62	61	60	59	58	57	56	55	54	53	52	51	50	49	48	47	46	45	44	43	42	41	40	39	38	37	36	35	34	33	32
<b>DW7</b>	ISOIN_7[11:0]											ISOIN_6[11:0]											ISOIN_5[11:4]									
<b>DW5</b>	ISOIN_2[7:0]							ISOIN_1[11:0]														ISOIN_0[11:0]										
<b>DW3</b>	A	H	B	reserved											NrBytesTransferred[14:0] (32 kB – 1 B for high-speed)																	
<b>DW1</b>	reserved													S	EP Type [1:0]	Token [1:0]	DeviceAddress[6:0]						EndPt[3:1]									
Bit	31	30	29	28	27	26	25	24	23	22	21	20	19	18	17	16	15	14	13	12	11	10	9	8	7	6	5	4	3	2	1	0
<b>DW6</b>	ISOIN_5[3:0]			ISOIN_4[11:0]														ISOIN_3[11:0]											ISOIN_2[11:8]			
<b>DW4</b>	Status7[2:0]		Status6[2:0]		Status5[2:0]		Status4[2:0]		Status3[2:0]		Status2[2:0]		Status1[2:0]		Status0[2:0]		μSA[7:0]															
<b>DW2</b>	reserved								DataStartAddress[15:0]														μFrame[7:0]									
<b>DW0</b>	[2]	Mult [1:0]		MaxPacketLength[10:0]										NrBytesToTransfer[14:0]														[1]	V			

[1] Reserved.

[2] EndPt[0].



**Table 72. High-speed isochronous IN and OUT: bit description**

Bit	Symbol	Access	Value	Description
<b>DW7</b>				
63 to 52	ISOIN_7[11:0]	<b>HW</b> — writes	-	Bytes received during $\mu$ SOF7, if $\mu$ SA[7] is set to 1 and frame number is correct.
51 to 40	ISOIN_6[11:0]	<b>HW</b> — writes	-	Bytes received during $\mu$ SOF6, if $\mu$ SA[6] is set to 1 and frame number is correct.
39 to 32	ISOIN_5[11:4]	<b>HW</b> — writes	-	Bytes received during $\mu$ SOF5 (bits 11 to 4), if $\mu$ SA[5] is set to 1 and frame number is correct.
<b>DW6</b>				
31 to 28	ISOIN_5[3:0]	<b>HW</b> — writes	-	Bytes received during $\mu$ SOF5 (bits 3 to 0), if $\mu$ SA[5] is set to 1 and frame number is correct.
27 to 16	ISOIN_4[11:0]	<b>HW</b> — writes	-	Bytes received during $\mu$ SOF4, if $\mu$ SA[4] is set to 1 and frame number is correct.
15 to 4	ISOIN_3[11:0]	<b>HW</b> — writes	-	Bytes received during $\mu$ SOF3, if $\mu$ SA[3] is set to 1 and frame number is correct.
3 to 0	ISOIN_2[11:8]	<b>HW</b> — writes	-	Bytes received during $\mu$ SOF2 (bits 11 to 8), if $\mu$ SA[2] is set to 1 and frame number is correct.
<b>DW5</b>				
63 to 56	ISOIN_2[7:0]	<b>HW</b> — writes	-	Bytes received during $\mu$ SOF2 (bits 7 to 0), if $\mu$ SA[2] is set to 1 and frame number is correct.
55 to 44	ISOIN_1[11:0]	<b>HW</b> — writes	-	Bytes received during $\mu$ SOF1, if $\mu$ SA[1] is set to 1 and frame number is correct.
43 to 32	ISOIN_0[11:0]	<b>HW</b> — writes	-	Bytes received during $\mu$ SOF0, if $\mu$ SA[0] is set to 1 and frame number is correct.
<b>DW4</b>				
31 to 29	Status7[2:0]	<b>HW</b> — writes	-	ISO IN or OUT status at $\mu$ SOF7
28 to 26	Status6[2:0]	<b>HW</b> — writes	-	ISO IN or OUT status at $\mu$ SOF6
25 to 23	Status5[2:0]	<b>HW</b> — writes	-	ISO IN or OUT status at $\mu$ SOF5
22 to 20	Status4[2:0]	<b>HW</b> — writes	-	ISO IN or OUT status at $\mu$ SOF4
19 to 17	Status3[2:0]	<b>HW</b> — writes	-	ISO IN or OUT status at $\mu$ SOF3
16 to 14	Status2[2:0]	<b>HW</b> — writes	-	ISO IN or OUT status at $\mu$ SOF2
13 to 11	Status1[2:0]	<b>HW</b> — writes	-	ISO IN or OUT status at $\mu$ SOF1
10 to 8	Status0[2:0]	<b>HW</b> — writes	-	Status of the payload on the USB bus for this $\mu$ SOF after ISO has been delivered. <b>Bit 0</b> — Transaction error (IN and OUT) <b>Bit 1</b> — Babble (IN token only) <b>Bit 2</b> — Underrun (OUT token only)
7 to 0	$\mu$ SA[7:0]	<b>SW</b> — writes (0 $\rightarrow$ 1) <b>HW</b> — writes (1 $\rightarrow$ 0) After processing	-	<b><math>\mu</math>SOF Active:</b> When the frame number of bits DW1[7:3] match the frame number of USB bus, these bits are checked for 1 before they are sent for $\mu$ SOF. For example: If $\mu$ SA[7:0] = 1, 1, 1, 1, 1, 1, 1, 1: send ISO every $\mu$ SOF of the entire millisecond. If $\mu$ SA[7:0] = 0, 1, 0, 1, 0, 1, 0, 1: send ISO only on $\mu$ SOF0, $\mu$ SOF2, $\mu$ SOF4 and $\mu$ SOF6.
<b>DW3</b>				
63	A	<b>SW</b> — sets	-	<b>Active:</b> This bit is the same as the Valid bit.
62	H	<b>HW</b> — writes	-	<b>Halt:</b> Only one bit for the entire millisecond. When this bit is set, the Valid bit is reset. The device decides to stall an endpoint.

**Table 72. High-speed isochronous IN and OUT: bit description ...continued**

Bit	Symbol	Access	Value	Description
61	B	<b>HW</b> — writes	-	<b>Babble:</b> Not applicable here.
60 to 47	reserved	-	0	Set to 0 for isochronous.
46 to 32	NrBytes Transferred [14:0]	<b>HW</b> — writes	-	<b>Number of Bytes Transferred:</b> This field indicates the number of bytes sent or received for this transaction. If Mult[1:0] is greater than one, it is possible to store intermediate results in this field. NrBytesTransferred[14:0] is 32 kB – 1 B per PTD.
<b>DW2</b>				
31 to 24	reserved	-	0	Set to 0 for isochronous.
23 to 8	DataStart Address[15:0]	<b>SW</b> — writes	-	<b>Data Start Address:</b> This is the start address for data that will be sent or received on or from the USB bus. This is the internal memory address and not the direct CPU address. RAM address = (CPU address – 400h) / 8
7 to 0	μFrame[7:0]	<b>SW</b> — writes	-	<b>Bits 2 to 0</b> — Don't care <b>Bits 7 to 3</b> — Frame number that this PTD will be sent for ISO OUT or IN
<b>DW1</b>				
63 to 47	reserved	-	-	-
46	S	<b>SW</b> — writes	-	This bit indicates whether a split transaction has to be executed. <b>0</b> — High-speed transaction <b>1</b> — Split transaction
45 to 44	EPTtype[1:0]	<b>SW</b> — writes	-	<b>Endpoint type:</b> <b>01</b> — Isochronous
43 to 42	Token[1:0]	<b>SW</b> — writes	-	<b>Token:</b> This field indicates the token PID for this transaction: <b>00</b> — OUT <b>01</b> — IN
41 to 35	Device Address[6:0]	<b>SW</b> — writes	-	<b>Device Address:</b> This is the USB address of the function containing the endpoint that is referred to by this buffer.
34 to 32	EndPt[3:1]	<b>SW</b> — writes	-	<b>Endpoint:</b> This is the USB address of the endpoint within the function.
<b>DW0</b>				
31	EndPt[0]	<b>SW</b> — writes	-	<b>Endpoint:</b> This is the USB address of the endpoint within the function.
30 to 29	Mult[1:0]	<b>SW</b> — writes	-	This field is a multiplier counter used by the host controller as the number of successive packets the host controller may submit to the endpoint in the current execution. For details, refer to Appendix D of <a href="#">Ref. 2 “Enhanced Host Controller Interface Specification for Universal Serial Bus Rev. 1.0”</a> .
28 to 18	MaxPacket Length[10:0]	<b>SW</b> — writes	-	<b>Maximum Packet Length:</b> This field indicates the maximum number of bytes that can be sent to or received from the endpoint in a single data packet. The maximum packet size for an isochronous transfer is 1024 bytes. The maximum packet size for the isochronous transfer is also variable at any whole number.

**Table 72. High-speed isochronous IN and OUT: bit description ...continued**

Bit	Symbol	Access	Value	Description
17 to 3	NrBytesTo Transfer[14:0]	<b>SW</b> — writes	-	<b>Number of Bytes Transferred:</b> This field indicates the number of bytes that can be transferred by this data structure. It is used to indicate the depth of the DATA field (32 kB – 1 B).
2 to 1	reserved	-	-	-
0	V	<b>HW</b> — resets <b>SW</b> — sets	-	<b>0</b> — This bit is deactivated when the entire PTD is executed, or when a fatal error is encountered. <b>1</b> — Software updates to one when there is payload to be sent or received. The current PTD is active.

### 9.3 High-speed interrupt IN and OUT

[Table 73](#) shows the bit allocation of the high-speed interrupt IN and OUT, periodic Transfer Descriptor (pTD).

**Table 73. High-speed interrupt IN and OUT: bit allocation**

Bit	63	62	61	60	59	58	57	56	55	54	53	52	51	50	49	48	47	46	45	44	43	42	41	40	39	38	37	36	35	34	33	32	
<b>DW7</b>	INT_IN_7[11:0]											INT_IN_6[11:0]											INT_IN_5[11:4]										
<b>DW5</b>	INT_IN_2[7:0]							INT_IN_1[11:0]														INT_IN_0[11:0]											
<b>DW3</b>	A	H	reserved				DT	Cerr [1:0]	reserved											NrBytesTransferred[14:0] (32 kB – 1 B for high-speed)													
<b>DW1</b>	reserved													S	EP Type [1:0]	Token [1:0]	DeviceAddress[6:0]							EndPt[3:1]									
Bit	31	30	29	28	27	26	25	24	23	22	21	20	19	18	17	16	15	14	13	12	11	10	9	8	7	6	5	4	3	2	1	0	
<b>DW6</b>	INT_IN_5[3:0]			INT_IN_4[11:0]														INT_IN_3[11:0]											INT_IN_2[11:8]				
<b>DW4</b>	Status7[2:0]		Status6[2:0]		Status5[2:0]		Status4[2:0]		Status3[2:0]		Status2[2:0]		Status1[2:0]		Status0[2:0]		μSA[7:0]																
<b>DW2</b>	reserved								DataStartAddress[15:0]														μFrame[7:0]										
<b>DW0</b>	[2]	Mult [1:0]		MaxPacketLength[10:0]											NrBytesToTransfer[14:0]														[1]	V			

[1] Reserved.

[2] EndPt[0].

**Table 74. High-speed interrupt IN and OUT: bit description**

Bit	Symbol	Access	Value	Description
<b>DW7</b>				
63 to 52	INT_IN_7[11:0]	HW — writes	-	Bytes received during $\mu$ SOF7, if $\mu$ SA[7] is set to 1 and frame number is correct.
51 to 40	INT_IN_6[11:0]	HW — writes	-	Bytes received during $\mu$ SOF6, if $\mu$ SA[6] is set to 1 and frame number is correct.
39 to 32	INT_IN_5[11:4]	HW — writes	-	Bytes received during $\mu$ SOF5 (bits 11 to 4), if $\mu$ SA[5] is set to 1 and frame number is correct.
<b>DW6</b>				
31 to 28	INT_IN_5[3:0]	HW — writes	-	Bytes received during $\mu$ SOF5 (bits 3 to 0), if $\mu$ SA[5] is set to 1 and frame number is correct.
27 to 16	INT_IN_4[11:0]	HW — writes	-	Bytes received during $\mu$ SOF4, if $\mu$ SA[4] is set to 1 and frame number is correct.
15 to 4	INT_IN_3[11:0]	HW — writes	-	Bytes received during $\mu$ SOF3, if $\mu$ SA[3] is set to 1 and frame number is correct.
3 to 0	INT_IN_2[11:8]	HW — writes	-	Bytes received during $\mu$ SOF2 (bits 11 to 8), if $\mu$ SA[2] is set to 1 and frame number is correct.
<b>DW5</b>				
63 to 56	INT_IN_2[7:0]	HW — writes	-	Bytes received during $\mu$ SOF2 (bits 7 to 0), if $\mu$ SA[2] is set to 1 and frame number is correct.
55 to 44	INT_IN_1[11:0]	HW — writes	-	Bytes received during $\mu$ SOF1, if $\mu$ SA[1] is set to 1 and frame number is correct.
43 to 32	INT_IN_0[11:0]	HW — writes	-	Bytes received during $\mu$ SOF0, if $\mu$ SA[0] is set to 1 and frame number is correct.
<b>DW4</b>				
31 to 29	Status7[2:0]	HW — writes	-	INT IN or OUT status of $\mu$ SOF7
28 to 26	Status6[2:0]	HW — writes	-	INT IN or OUT status of $\mu$ SOF6
25 to 23	Status5[2:0]	HW — writes	-	INT IN or OUT status of $\mu$ SOF5
22 to 20	Status4[2:0]	HW — writes	-	INT IN or OUT status of $\mu$ SOF4
19 to 17	Status3[2:0]	HW — writes	-	INT IN or OUT status of $\mu$ SOF3
16 to 14	Status2[2:0]	HW — writes	-	INT IN or OUT status of $\mu$ SOF2
13 to 11	Status1[2:0]	HW — writes	-	INT IN or OUT status of $\mu$ SOF1
10 to 8	Status0[2:0]	HW — writes	-	Status of the payload on the USB bus for this $\mu$ SOF after INT has been delivered. <b>Bit 0</b> — Transaction error (IN and OUT) <b>Bit 1</b> — Babble (IN token only) <b>Bit 2</b> — Underrun (OUT token only)
7 to 0	$\mu$ SA[7:0]	SW — writes (0 → 1) HW — writes (1 → 0) After processing	-	When the frame number of bits DW2[7:3] match the frame number of the USB bus, these bits are checked for 1 before they are sent for $\mu$ SOF. For example: When $\mu$ SA[7:0] = 1, 1, 1, 1, 1, 1, 1, 1: send INT for every $\mu$ SOF of the entire millisecond. When $\mu$ SA[7:0] = 0, 1, 0, 1, 0, 1, 0, 1: send INT for $\mu$ SOF0, $\mu$ SOF2, $\mu$ SOF4 and $\mu$ SOF6. When $\mu$ SA[7:0] = 1, 0, 0, 0, 1, 0, 0, 0: send INT for every fourth $\mu$ SOF.

**Table 74. High-speed interrupt IN and OUT: bit description ...continued**

Bit	Symbol	Access	Value	Description
<b>DW3</b>				
63	A	<b>HW</b> — writes <b>SW</b> — writes	-	<b>Active:</b> Write the same value as that in V.
62	H	<b>HW</b> — writes	-	<b>Halt:</b> Transaction is halted.
61 to 58	reserved	-	-	-
57	DT	<b>HW</b> — writes <b>SW</b> — writes	-	<b>Data Toggle:</b> Set the Data Toggle bit to start the PTD. Software writes the current transaction toggle value. Hardware writes the next transaction toggle value.
56 to 55	Cerr[1:0]	<b>HW</b> — writes <b>SW</b> — writes	-	<b>Error Counter.</b> This field corresponds to the Cerr[1:0] field in the TD. The default value of this field is zero for isochronous transactions.
54 to 47	reserved	-	-	-
46 to 32	NrBytes Transferred [14:0]	<b>HW</b> — writes	-	<b>Number of Bytes Transferred:</b> This field indicates the number of bytes sent or received for this transaction. If Mult[1:0] is greater than one, it is possible to store intermediate results in this field.
<b>DW2</b>				
31 to 24	reserved	-	-	-
23 to 8	DataStart Address[15:0]	<b>SW</b> — writes	-	<b>Data Start Address:</b> This is the start address for data that will be sent or received on or from the USB bus. This is the internal memory address and not the direct CPU address. RAM address = (CPU address – 400h) / 8
7 to 0	μFrame[7:0]	<b>SW</b> — writes	-	Bits 7 to 3 represent the polling rate in milliseconds. The INT polling rate is defined as $2^{(b-1)} \mu\text{SOF}$ , where b is 1 to 9. When b is 1, 2, 3 or 4, use μSA to define polling because the rate is equal to or less than 1 ms. Bits 7 to 3 are set to 0. Polling checks μSA bits for μSOF rates. See <a href="#">Table 75</a> .
<b>DW1</b>				
63 to 47	reserved	-	-	-
46	S	<b>SW</b> — writes	-	This bit indicates if a split transaction has to be executed: <b>0</b> — High-speed transaction <b>1</b> — Split transaction
45 to 44	EPTYPE[1:0]	<b>SW</b> — writes	-	<b>Endpoint type:</b> <b>11</b> — Interrupt
43 to 42	Token[1:0]	<b>SW</b> — writes	-	<b>Token:</b> This field indicates the token PID for this transaction: <b>00</b> — OUT <b>01</b> — IN
41 to 35	DeviceAddress [6:0]	<b>SW</b> — writes	-	<b>Device Address:</b> This is the USB address of the function containing the endpoint that is referred to by the buffer.
34 to 32	EndPt[3:1]	<b>SW</b> — writes	-	<b>Endpoint:</b> This is the USB address of the endpoint within the function.
<b>DW0</b>				
31	EndPt[0]	<b>SW</b> — writes	-	<b>Endpoint:</b> This is the USB address of the endpoint within the function.

**Table 74. High-speed interrupt IN and OUT: bit description ...continued**

Bit	Symbol	Access	Value	Description
30 to 29	Mult[1:0]	SW — writes	-	<p><b>Multiplier:</b> This field is a multiplier counter used by the host controller as the number of successive packets the host controller may submit to the endpoint in the current execution.</p> <p>Set this field to 01b. You can also set it to 11b and 10b, depending on your application. 00b is undefined.</p>
28 to 18	MaxPacket Length[10:0]	SW — writes	-	<p><b>Maximum Packet Length:</b> This field indicates the maximum number of bytes that can be sent to or received from the endpoint in a single data packet.</p>
17 to 3	NrBytesTo Transfer[14:0]	SW — writes	-	<p><b>Number of Bytes to Transfer:</b> This field indicates the number of bytes that can be transferred by this data structure. It is used to indicate the depth of the DATA field (32 kB – 1 B).</p>
2 to 1	reserved	-	-	-
0	V	SW — sets HW — resets	-	<p><b>Valid:</b></p> <p><b>0</b> — This bit is deactivated when the entire PTD is executed, or when a fatal error is encountered.</p> <p><b>1</b> — Software updates to one when there is payload to be sent or received. The current PTD is active.</p>

**Table 75. Microframe description**

b	Rate	μFrame[7:3]	μSA[7:0]
1	1 μSOF	0 0000	1111 1111
2	2 μSOF	0 0000	1010 1010 or 0101 0101
3	4 μSOF	0 0000	any 2 bits set
4	1 ms	0 0000	any 1 bit set
5	2 ms	0 0001	any 1 bit set
6	4 ms	0 0010 to 0 0011	any 1 bit set
7	8 ms	0 0100 to 0 0111	any 1 bit set
8	16 ms	0 1000 to 0 1111	any 1 bit set
9	32 ms	1 0000 to 1 1111	any 1 bit set

## 9.4 Start and complete split for bulk

Table 76 shows the bit allocation of Start Split (SS) and Complete Split (CS) for bulk, asynchronous Start Split and Complete Split (SS/CS) Transfer Descriptor (TD).

**Table 76. Start and complete split for bulk: bit allocation**

Bit	63	62	61	60	59	58	57	56	55	54	53	52	51	50	49	48	47	46	45	44	43	42	41	40	39	38	37	36	35	34	33	32
<b>DW7</b>	reserved																															
<b>DW5</b>	reserved																															
<b>DW3</b>	A	H	B	X	SC	[1]	DT	Cerr [1:0]	NakCnt[3:0]			reserved				NrBytesTransferred[14:0]																
<b>DW1</b>	HubAddress[6:0]						PortNumber[6:0]						SE[1:0]	[1]	S	EP Type [1:0]	Token [1:0]	DeviceAddress[6:0]						EndPt[3:1]								
Bit	31	30	29	28	27	26	25	24	23	22	21	20	19	18	17	16	15	14	13	12	11	10	9	8	7	6	5	4	3	2	1	0
<b>DW6</b>	reserved																															
<b>DW4</b>	reserved																								J	NextPTDAddress[4:0]						
<b>DW2</b>	reserved		RL[3:0]			[1]	DataStartAddress[15:0]														reserved											
<b>DW0</b>	[2]	[1]	MaxPacketLength[10:0]										NrBytesToTransfer[14:0]														[1]	V				

[1] Reserved.

[2] EndPt[0].



**Table 77. Start and complete split for bulk: bit description**

Bit	Symbol	Access	Value	Description
<b>DW7</b>				
63 to 32	reserved	-	-	-
<b>DW6</b>				
31 to 0	reserved	-	-	-
<b>DW5</b>				
63 to 32	reserved	-	-	-
<b>DW4</b>				
31 to 6	reserved	-	-	-
5	J	<b>SW</b> — writes	-	<b>0</b> — To increment the PTD pointer. <b>1</b> — To enable the next PTD branching.
4 to 0	NextPTDPointer [4:0]	<b>SW</b> — writes	-	Next PTD branching assigned by the PTD pointer.
<b>DW3</b>				
63	A	<b>SW</b> — sets <b>HW</b> — resets	-	<b>Active:</b> Write the same value as that in V.
62	H	<b>HW</b> — writes	-	<b>Halt:</b> This bit corresponds to the Halt bit of the Status field of TD.
61	B	<b>HW</b> — writes	-	<b>Babble:</b> This bit corresponds to the Babble Detected bit in the Status field of iTD, siTD or TD. <b>1</b> — When babbling is detected, A and V are set to 0.
60	X	<b>HW</b> — writes	-	<b>Transaction Error:</b> This bit corresponds to the Transaction Error bit in the status field.
		<b>SW</b> — writes	-	<b>0</b> — Before scheduling
59	SC	<b>SW</b> — writes 0 <b>HW</b> — updates	-	<b>Start/Complete:</b> <b>0</b> — Start split <b>1</b> — Complete split
58	reserved	-	-	-
57	DT	<b>HW</b> — writes <b>SW</b> — writes	-	<b>Data Toggle:</b> Set the Data Toggle bit to start for the PTD.
56 to 55	Cerr[1:0]	<b>HW</b> — updates <b>SW</b> — writes	-	<b>Error Counter:</b> This field contains the error count for asynchronous start and complete split (SS/CS) TD. When an error has no response or bad response, Cerr[1:0] will be decremented to zero and then Valid will be set to zero. A NAK or NYET will reset Cerr[1:0]. For details, refer to Section 4.12.1.2 of <a href="#">Ref. 2 “Enhanced Host Controller Interface Specification for Universal Serial Bus Rev. 1.0”</a> .  If retry has insufficient time at the beginning of a new SOF, the first PTD must be this retry. This can be accomplished if aperiodic PTD is not advanced.
54 to 51	NakCnt[3:0]	<b>HW</b> — writes <b>SW</b> — writes	-	<b>NAK Counter:</b> The V bit is reset if NakCnt decrements to zero and RL is a nonzero value. Not applicable to isochronous split transactions.
50 to 47	reserved	-	-	-
46 to 32	NrBytesTransferred [14:0]	<b>HW</b> — writes	-	<b>Number of Bytes Transferred:</b> This field indicates the number of bytes sent or received for this transaction.
<b>DW2</b>				

**Table 77. Start and complete split for bulk: bit description ...continued**

Bit	Symbol	Access	Value	Description
31 to 29	reserved	-	-	-
28 to 25	RL[3:0]	<b>SW</b> — writes	-	<b>Reload:</b> If RL is set to 0h, hardware ignores the NakCnt value. Set RL and NakCnt to the same value before a transaction. For full-speed and low-speed transactions, set this field to 0000b. Not applicable to isochronous start split and complete split.
24	reserved	-	-	-
23 to 8	DataStartAddress [15:0]	<b>SW</b> — writes	-	<b>Data Start Address:</b> This is the start address for data that will be sent or received on or from the USB bus. This is the internal memory address and not the direct CPU address. RAM address = (CPU address – 400h) / 8
7 to 0	reserved	-	-	-
<b>DW1</b>				
63 to 57	HubAddress[6:0]	<b>SW</b> — writes	-	<b>Hub Address:</b> This indicates the hub address.
56 to 50	PortNumber[6:0]	<b>SW</b> — writes	-	<b>Port Number:</b> This indicates the port number of the hub or embedded TT.
49 to 48	SE[1:0]	<b>SW</b> — writes	-	This depends on the endpoint type and direction. It is valid only for split transactions. <a href="#">Table 78</a> applies to start split and complete split only.
47	reserved	-	-	-
46	S	<b>SW</b> — writes	-	This bit indicates whether a split transaction has to be executed: <b>0</b> — High-speed transaction <b>1</b> — Split transaction
45 to 44	EPTYPE[1:0]	<b>SW</b> — writes	-	<b>Endpoint Type:</b> <b>00</b> — Control <b>10</b> — Bulk
43 to 42	Token[1:0]	<b>SW</b> — writes	-	<b>Token:</b> This field indicates the PID for this transaction. <b>00</b> — OUT <b>01</b> — IN <b>10</b> — SETUP
41 to 35	DeviceAddress[6:0]	<b>SW</b> — writes	-	<b>Device Address:</b> This is the USB address of the function containing the endpoint that is referred to by this buffer.
34 to 32	EndPt[3:1]	<b>SW</b> — writes	-	<b>Endpoint:</b> This is the USB address of the endpoint within the function.
<b>DW0</b>				
31	EndPt[0]	<b>SW</b> — writes	-	<b>Endpoint:</b> This is the USB address of the endpoint within the function.
30 to 29	reserved	-	-	-
28 to 18	MaximumPacket Length[10:0]	<b>SW</b> — writes	-	<b>Maximum Packet Length:</b> This field indicates the maximum number of bytes that can be sent to or received from an endpoint in a single data packet. The maximum packet size for full-speed is 64 bytes as defined in the <a href="#">Ref. 1 “Universal Serial Bus Specification Rev. 2.0”</a> .

**Table 77. Start and complete split for bulk: bit description ...continued**

Bit	Symbol	Access	Value	Description
17 to 3	NrBytesToTransfer [14:0]	<b>SW</b> — writes	-	<b>Number of Bytes to Transfer:</b> This field indicates the number of bytes that can be transferred by this data structure. It is used to indicate the depth of the DATA field.
2 to 1	reserved	-	-	-
0	V	<b>SW</b> — sets <b>HW</b> — resets	-	<b>Valid:</b> <b>0</b> — This bit is deactivated when the entire PTD is executed, or when a fatal error is encountered. <b>1</b> — Software updates to one when there is payload to be sent or received. The current PTD is active.

**Table 78. SE description**

Bulk	Control	S	E	Remarks
I/O	I/O	1	0	low-speed
I/O	I/O	0	0	full-speed

## 9.5 Start and complete split for isochronous

Table 79 shows the bit allocation for start and complete split for isochronous, split isochronous Transfer Descriptor (siTD).

**Table 79. Start and complete split for isochronous: bit allocation**

Bit	63	62	61	60	59	58	57	56	55	54	53	52	51	50	49	48	47	46	45	44	43	42	41	40	39	38	37	36	35	34	33	32
<b>DW7</b>	reserved																								ISO_IN_7[7:0]							
<b>DW5</b>	ISO_IN_2[7:0]						ISO_IN_1[7:0]						ISO_IN_0[7:0]						μSCS[7:0] <sup>[2]</sup>													
<b>DW3</b>	A	H	B	X	SC	<sup>[1]</sup>	DT	reserved														NrBytesTransferred[11:0]										
<b>DW1</b>	HubAddress[6:0]						PortNumber[6:0]						reserved		S	EP Type [1:0]	Token [1:0]	DeviceAddress[6:0]				EndPt[3:1]										
Bit	31	30	29	28	27	26	25	24	23	22	21	20	19	18	17	16	15	14	13	12	11	10	9	8	7	6	5	4	3	2	1	0
<b>DW6</b>	ISO_IN_6[7:0]						ISO_IN_5[7:0]						ISO_IN_4[7:0]						ISO_IN_3[7:0]													
<b>DW4</b>	Status7[2:0]		Status6[2:0]		Status5[2:0]		Status4[2:0]		Status3[2:0]		Status2[2:0]		Status1[2:0]		Status0[2:0]		μSA[7:0]															
<b>DW2</b>	reserved						DataStartAddress[15:0]														μFrame[7:0] (full-speed)											
<b>DW0</b>	<sup>[2]</sup>	<sup>[1]</sup>	TT_MPS_Len[10:0]						NrBytesToTransfer[14:0] (1 kB for full-speed)														<sup>[1]</sup>	V								

[1] Reserved.

[2] EndPt[0].

**Table 80. Start and complete split for isochronous: bit description**

Bit	Symbol	Access	Value	Description
<b>DW7</b>				
63 to 40	reserved	-	-	-
39 to 32	ISO_IN_7[7:0]	<b>HW</b> — writes	-	Bytes received during $\mu$ SOF7, if $\mu$ SA[7] is set to 1 and frame number is correct.
<b>DW6</b>				
31 to 24	ISO_IN_6[7:0]	<b>HW</b> — writes	-	Bytes received during $\mu$ SOF6, if $\mu$ SA[6] is set to 1 and frame number is correct.
23 to 16	ISO_IN_5[7:0]	<b>HW</b> — writes	-	Bytes received during $\mu$ SOF5, if $\mu$ SA[5] is set to 1 and frame number is correct.
15 to 8	ISO_IN_4[7:0]	<b>HW</b> — writes	-	Bytes received during $\mu$ SOF4, if $\mu$ SA[4] is set to 1 and frame number is correct.
7 to 0	ISO_IN_3[7:0]	<b>HW</b> — writes	-	Bytes received during $\mu$ SOF3, if $\mu$ SA[3] is set to 1 and frame number is correct.
<b>DW5</b>				
63 to 56	ISO_IN_2[7:0]	<b>HW</b> — writes	-	Bytes received during $\mu$ SOF2 (bits 7 to 0), if $\mu$ SA[2] is set to 1 and frame number is correct.
55 to 48	ISO_IN_1[7:0]	<b>HW</b> — writes	-	Bytes received during $\mu$ SOF1, if $\mu$ SA[1] is set to 1 and frame number is correct.
47 to 40	ISO_IN_0[7:0]	<b>HW</b> — writes	-	Bytes received during $\mu$ SOF0 if $\mu$ SA[0] is set to 1 and frame number is correct.
39 to 32	$\mu$ SCS[7:0]	<b>SW</b> — writes (0 $\rightarrow$ 1) <b>HW</b> — writes (1 $\rightarrow$ 0) After processing	-	All bits can be set to one for every transfer. It specifies which $\mu$ SOF the complete split needs to be sent. Valid only for IN. Start split and complete split active bits, $\mu$ SA = 0000 0001, $\mu$ SCS = 0000 0100, will cause SS to execute in $\mu$ Frame0 and CS in $\mu$ Frame2.
<b>DW4</b>				
31 to 29	Status7[2:0]	<b>HW</b> — writes	-	Isochronous IN or OUT status of $\mu$ SOF7
28 to 26	Status6[2:0]	<b>HW</b> — writes	-	Isochronous IN or OUT status of $\mu$ SOF6
25 to 23	Status5[2:0]	<b>HW</b> — writes	-	Isochronous IN or OUT status of $\mu$ SOF5
22 to 20	Status4[2:0]	<b>HW</b> — writes	-	Isochronous IN or OUT status of $\mu$ SOF4
19 to 17	Status3[2:0]	<b>HW</b> — writes	-	Isochronous IN or OUT status of $\mu$ SOF3
16 to 14	Status2[2:0]	<b>HW</b> — writes	-	Isochronous IN or OUT status of $\mu$ SOF2
13 to 11	Status1[2:0]	<b>HW</b> — writes	-	Isochronous IN or OUT status of $\mu$ SOF1
10 to 8	Status0[2:0]	<b>HW</b> — writes	-	Isochronous IN or OUT status of $\mu$ SOF0 <b>Bit 0</b> — Transaction error (IN and OUT) <b>Bit 1</b> — Babble (IN token only) <b>Bit 2</b> — Underrun (OUT token only)
7 to 0	$\mu$ SA[7:0]	<b>SW</b> — writes (0 $\rightarrow$ 1) <b>HW</b> — writes (1 $\rightarrow$ 0) After processing	-	Specifies which $\mu$ SOF the start split needs to be placed. <b>For OUT token:</b> When the frame number of bits DW2[7:3] matches the frame number of the USB bus, these bits are checked for one before they are sent for the $\mu$ SOF. <b>For IN token:</b> Only $\mu$ SOF0, $\mu$ SOF1, $\mu$ SOF2 or $\mu$ SOF3 can be set to 1. Nothing can be set for $\mu$ SOF4 and above.

### DW3

**Table 80. Start and complete split for isochronous: bit description ...continued**

Bit	Symbol	Access	Value	Description
63	A	<b>SW</b> — sets <b>HW</b> — resets	-	<b>Active:</b> Write the same value as that in V.
62	H	<b>HW</b> — writes	-	<b>Halt:</b> The Halt bit is set when any microframe transfer status has a stalled or halted condition.
61	B	<b>HW</b> — writes	-	<b>Babble:</b> This bit corresponds to bit 1 of Status0 to Status7 for every microframe transfer status.
60	X	<b>HW</b> — writes	-	<b>Transaction Error:</b> This bit corresponds to bit 0 of Status0 to Status7 for every microframe transfer status.
59	SC	<b>SW</b> — writes 0 <b>HW</b> — updates	-	<b>Start/Complete:</b> <b>0</b> — Start split <b>1</b> — Complete split
58	reserved	-	-	-
57	DT	<b>HW</b> — writes <b>SW</b> — writes	-	<b>Data Toggle:</b> Set the Data Toggle bit to start for the PTD.
56 to 44	reserved	-	-	-
43 to 32	NrBytes Transferred[11:0]	<b>HW</b> — writes	-	<b>Number of Bytes Transferred:</b> This field indicates the number of bytes sent or received for this transaction.
<b>DW2</b>				
31 to 24	reserved	-	-	-
23 to 8	DataStart Address[15:0]	<b>SW</b> — writes	-	<b>Data Start Address:</b> This is the start address for data that will be sent or received on or from the USB bus. This is the internal memory address and not the CPU address.
7 to 0	μFrame[7:0]	<b>SW</b> — writes	-	Bits 7 to 3 determine which frame to execute.
<b>DW1</b>				
63 to 57	HubAddress [6:0]	<b>SW</b> — writes	-	<b>Hub Address:</b> This indicates the hub address.
56 to 50	PortNumber [6:0]	<b>SW</b> — writes	-	<b>Port Number:</b> This indicates the port number of the hub or embedded TT.
49 to 47	reserved	-	-	-
46	S	<b>SW</b> — writes	-	This bit indicates whether a split transaction has to be executed: <b>0</b> — High-speed transaction <b>1</b> — Split transaction
45 to 44	EPTYPE[1:0]	<b>SW</b> — writes	-	Transaction type: <b>01</b> — Isochronous
43 to 42	Token[1:0]	<b>SW</b> — writes	-	Token PID for this transaction: <b>00</b> — OUT <b>01</b> — IN
41 to 35	DeviceAddress [6:0]	<b>SW</b> — writes	-	<b>Device Address:</b> This is the USB address of the function containing the endpoint that is referred to by this buffer.
34 to 32	EndPt[3:1]	<b>SW</b> — writes	-	<b>Endpoint:</b> This is the USB address of the endpoint within the function.
<b>DW0</b>				
31	EndPt[0]	<b>SW</b> — writes	-	<b>Endpoint:</b> This is the USB address of the endpoint within the function.

**Table 80. Start and complete split for isochronous: bit description ...continued**

Bit	Symbol	Access	Value	Description
30 to 29	reserved	-	-	-
28 to 18	TT_MPS_Len [10:0]	<b>SW</b> — writes	-	<b>Transaction Translator Maximum Packet Size Length:</b> This field indicates the maximum number of bytes that can be sent per start split, depending on the number of total bytes needed. If the total bytes to be sent for the entire millisecond is greater than 188 bytes, this field should be set to 188 bytes for an OUT token and 192 bytes for an IN token. Otherwise, this field should be equal to the total bytes sent.
17 to 3	NrBytesTo Transfer[14:0]	<b>SW</b> — writes	-	<b>Number of Bytes to Transfer:</b> This field indicates the number of bytes that can be transferred by this data structure. It is used to indicate the depth of the DATA field. This field is restricted to 1023 bytes because in siTD the maximum allowable payload for a full-speed device is 1023 bytes. This field indirectly becomes the maximum packet size of the downstream device.
2 to 1	reserved	-	-	-
0	V	<b>SW</b> — sets <b>HW</b> — resets	-	<b>0</b> — This bit is deactivated when the entire PTD is executed, or when a fatal error is encountered. <b>1</b> — Software updates to one when there is payload to be sent or received. The current PTD is active.

## 9.6 Start and complete split for interrupt

Table 81 shows the bit allocation of start and complete split for interrupt.

**Table 81. Start and complete split for interrupt: bit allocation**

Bit	63	62	61	60	59	58	57	56	55	54	53	52	51	50	49	48	47	46	45	44	43	42	41	40	39	38	37	36	35	34	33	32
<b>DW7</b>	reserved																							INT_IN_7[7:0]								
<b>DW5</b>	INT_IN_2[7:0]						INT_IN_1[7:0]						INT_IN_0[7:0]						μSCS[7:0]													
<b>DW3</b>	A	H	B	X	SC	[1]	DT	Cerr [1:0]	reserved											NrBytesTransferred[11:0] (4 kB for full-speed and low-speed)												
<b>DW1</b>	HubAddress[6:0]						PortNumber[6:0]						SE[1:0]	[1]	S	EP Type [1:0]	Token [1:0]	DeviceAddress[6:0]				EndPt[3:1]										
Bit	31	30	29	28	27	26	25	24	23	22	21	20	19	18	17	16	15	14	13	12	11	10	9	8	7	6	5	4	3	2	1	0
<b>DW6</b>	INT_IN_6[7:0]						INT_IN_5[7:0]						INT_IN_4[7:0]						INT_IN_3[7:0]													
<b>DW4</b>	Status7[2:0]		Status6[2:0]		Status5[2:0]		Status4[2:0]		Status3[2:0]		Status2[2:0]		Status1[2:0]		Status0[2:0]		μSA[7:0]															
<b>DW2</b>	reserved						DataStartAddress[15:0]											μFrame[7:0] (full-speed and low-speed)														
<b>DW0</b>	[2]	[1]	MaxPacketLength[10:0]						NrBytesToTransfer[14:0] (4 kB for full-speed and low-speed)											[1]	V											

[1] Reserved.

[2] EndPt[0].



**Table 82. Start and complete split for interrupt: bit description**

Bit	Symbol	Access	Value	Description
<b>DW7</b>				
63 to 40	reserved	-	-	-
39 to 32	INT_IN_7[7:0]	HW — writes	-	Bytes received during $\mu$ SOF7, if $\mu$ SA[7] is set to 1 and frame number is correct. The new value continuously overwrites the old value.
<b>DW6</b>				
31 to 24	INT_IN_6[7:0]	HW — writes	-	Bytes received during $\mu$ SOF6, if $\mu$ SA[6] is set to 1 and frame number is correct. The new value continuously overwrites the old value.
23 to 16	INT_IN_5[7:0]	HW — writes	-	Bytes received during $\mu$ SOF5, if $\mu$ SA[5] is set to 1 and frame number is correct. The new value continuously overwrites the old value.
15 to 8	INT_IN_4[7:0]	HW — writes	-	Bytes received during $\mu$ SOF4, if $\mu$ SA[4] is set to 1 and frame number is correct. The new value continuously overwrites the old value.
7 to 0	INT_IN_3[7:0]	HW — writes	-	Bytes received during $\mu$ SOF3, if $\mu$ SA[3] is set to 1 and frame number is correct. The new value continuously overwrites the old value.
<b>DW5</b>				
63 to 56	INT_IN_2[7:0]	HW — writes	-	Bytes received during $\mu$ SOF2 (bits 7 to 0), if $\mu$ SA[2] is set to 1 and frame number is correct. The new value continuously overwrites the old value.
55 to 48	INT_IN_1[7:0]	HW — writes	-	Bytes received during $\mu$ SOF1, if $\mu$ SA[1] is set to 1 and frame number is correct. The new value continuously overwrites the old value.
47 to 40	INT_IN_0[7:0]	HW — writes	-	Bytes received during $\mu$ SOF0 if $\mu$ SA[0] is set to 1 and frame number is correct. The new value continuously overwrites the old value.
39 to 32	$\mu$ SCS[7:0]	<b>SW</b> — writes (0 $\rightarrow$ 1) <b>HW</b> — writes (1 $\rightarrow$ 0) After processing	-	All bits can be set to one for every transfer. It specifies which $\mu$ SOF the complete split needs to be sent. Valid only for IN. Start split and complete split active bits, $\mu$ SA = 0000 0001, $\mu$ SCS = 0000 0100, will cause SS to execute in $\mu$ Frame0 and CS in $\mu$ Frame2.
<b>DW4</b>				
31 to 29	Status7[2:0]	HW — writes	-	Interrupt IN or OUT status of $\mu$ SOF7
28 to 26	Status6[2:0]	HW — writes	-	Interrupt IN or OUT status of $\mu$ SOF6
25 to 23	Status5[2:0]	HW — writes	-	Interrupt IN or OUT status of $\mu$ SOF5
22 to 20	Status4[2:0]	HW — writes	-	Interrupt IN or OUT status of $\mu$ SOF4
19 to 17	Status3[2:0]	HW — writes	-	Interrupt IN or OUT status of $\mu$ SOF3
16 to 14	Status2[2:0]	HW — writes	-	Interrupt IN or OUT status of $\mu$ SOF2
13 to 11	Status1[2:0]	HW — writes	-	Interrupt IN or OUT status of $\mu$ SOF1
10 to 8	Status0[2:0]	HW — writes	-	Interrupt IN or OUT status of $\mu$ SOF0
				<b>Bit 0</b> — Transaction error (IN and OUT)
				<b>Bit 1</b> — Babble (IN token only)
				<b>Bit 2</b> — Underrun (OUT token only)

**Table 82. Start and complete split for interrupt: bit description ...continued**

Bit	Symbol	Access	Value	Description
7 to 0	$\mu$ SA[7:0]	<b>SW</b> — writes (0 → 1) <b>HW</b> — writes (1 → 0) After processing	-	Specifies which $\mu$ SOF the start split needs to be placed. <b>For OUT token:</b> When the frame number of bits DW1[7:3] matches the frame number of the USB bus, these bits are checked for one before they are sent for the $\mu$ SOF. <b>For IN token:</b> Only $\mu$ SOF0, $\mu$ SOF1, $\mu$ SOF2 or $\mu$ SOF3 can be set to 1. Nothing can be set for $\mu$ SOF4 and above.
<b>DW3</b>				
63	A	<b>SW</b> — sets <b>HW</b> — resets	-	<b>Active:</b> Write the same value as that in V.
62	H	<b>HW</b> — writes	-	<b>Halt:</b> The Halt bit is set when any microframe transfer status has a stalled or halted condition.
61	B	<b>HW</b> — writes	-	<b>Babble:</b> This bit corresponds to bit 1 of Status0 to Status7 for every microframe transfer status.
60	X	<b>HW</b> — writes	-	<b>Transaction Error:</b> This bit corresponds to bit 0 of Status0 to Status7 for every microframe transfer status.
59	SC	<b>SW</b> — writes 0 <b>HW</b> — updates	-	<b>Start/Complete:</b> 0 — Start split 1 — Complete split
58	reserved	-	-	-
57	DT	<b>HW</b> — writes <b>SW</b> — writes	-	<b>Data Toggle:</b> For an interrupt transfer, set correct bit to start the PTD.
56 to 55	Cerr[1:0]	<b>HW</b> — writes <b>SW</b> — writes	-	<b>Error Counter:</b> This field corresponds to the Cerr[1:0] field in TD. 00 — The transaction will not retry. 11 — The transaction will retry three times. Hardware will decrement these values.
54 to 44	reserved	-	-	-
43 to 32	NrBytes Transferred[11:0]	<b>HW</b> — writes	-	<b>Number of Bytes Transferred:</b> This field indicates the number of bytes sent or received for this transaction.
<b>DW2</b>				
31 to 24	reserved	-	-	-
23 to 8	DataStart Address[15:0]	<b>SW</b> — writes	-	<b>Data Start Address:</b> This is the start address for data that will be sent or received on or from the USB bus. This is the internal memory address and not the CPU address.
7 to 0	$\mu$ Frame[7:0]	<b>SW</b> — writes	-	Bits 7 to 3 is the polling rate in milliseconds. Polling rate is defined as $2^{(b-1)}$ $\mu$ SOF; where b = 4 to 16. When b is 4, executed every millisecond. See <a href="#">Table 83</a> .
<b>DW1</b>				
63 to 57	HubAddress [6:0]	<b>SW</b> — writes	-	<b>Hub Address:</b> This indicates the hub address.
56 to 50	PortNumber[6:0]	<b>SW</b> — writes	-	<b>Port Number:</b> This indicates the port number of the hub or embedded TT.
49 to 48	SE[1:0]	<b>SW</b> — writes	-	This depends on the endpoint type and direction. It is valid only for split transactions. <a href="#">Table 84</a> applies to start split and complete split only.
47	reserved	-	-	-

**Table 82. Start and complete split for interrupt: bit description ...continued**

Bit	Symbol	Access	Value	Description
46	S	SW — writes	-	This bit indicates whether a split transaction has to be executed: <b>0</b> — High-speed transaction <b>1</b> — Split transaction
45 to 44	EPTyPe[1:0]	SW — writes	-	Transaction type: <b>11</b> — Interrupt
43 to 42	Token[1:0]	SW — writes	-	Token PID for this transaction: <b>00</b> — OUT <b>01</b> — IN
41 to 35	DeviceAddress [6:0]	SW — writes	-	<b>Device Address:</b> This is the USB address of the function containing the endpoint that is referred to by this buffer.
34 to 32	EndPt[3:1]	SW — writes	-	<b>Endpoint:</b> This is the USB address of the endpoint within the function.
<b>DW0</b>				
31	EndPt[0]	SW — writes	-	<b>Endpoint:</b> This is the USB address of the endpoint within the function.
30 to 29	reserved	-	-	-
28 to 18	MaxPacketLength [10:0]	SW — writes	-	<b>Maximum Packet Length:</b> This field indicates the maximum number of bytes that can be sent to or received from an endpoint in a single data packet. The maximum packet size for the full-speed and low-speed devices is 64 bytes as defined in <a href="#">Ref. 1 “Universal Serial Bus Specification Rev. 2.0”</a> .
17 to 3	NrBytesTo Transfer[14:0]	SW — writes	-	<b>Number of Bytes to Transfer:</b> This field indicates the number of bytes that can be transferred by this data structure. It is used to indicate the depth of the DATA field. The maximum total number of bytes for this transaction is 4 kB.
2 to 1	reserved	-	-	-
0	V	SW — sets HW — resets	-	<b>0</b> — This bit is deactivated when the entire PTD is executed, or when a fatal error is encountered. <b>1</b> — Software updates to one when there is payload to be sent or received. The current PTD is active.

**Table 83. Microframe description**

b	Rate	μFrame[7:3]
5	2 ms	0 0001
6	4 ms	0 0010 or 0 0011
7	8 ms	0 0100 or 0 0111
8	16 ms	0 1000 or 0 1111
9	32 ms	1 0000 or 1 1111

**Table 84. SE description**

Interrupt	S	E	Remarks
I/O	1	0	low-speed
I/O	0	0	full-speed

## 10. Power consumption

**Table 85. Power consumption**

Number of ports working	I <sub>CC</sub>
<b>One port working (high-speed)</b>	
V <sub>CC</sub> = 5.0 V, V <sub>CC(I/O)</sub> = 3.3 V	90 mA
V <sub>CC</sub> = 3.3 V, V <sub>CC(I/O)</sub> = 3.3 V	77 mA
V <sub>CC</sub> = 5.0 V, V <sub>CC(I/O)</sub> = 1.8 V	82 mA
V <sub>CC</sub> = 3.3 V, V <sub>CC(I/O)</sub> = 1.8 V	77 mA
<b>Two ports working (high-speed)</b>	
V <sub>CC</sub> = 5.0 V, V <sub>CC(I/O)</sub> = 3.3 V	110 mA
V <sub>CC</sub> = 3.3 V, V <sub>CC(I/O)</sub> = 3.3 V	97 mA
V <sub>CC</sub> = 5.0 V, V <sub>CC(I/O)</sub> = 1.8 V	102 mA
V <sub>CC</sub> = 3.3 V, V <sub>CC(I/O)</sub> = 1.8 V	97 mA
<b>Three ports working (high-speed)</b>	
V <sub>CC</sub> = 5.0 V, V <sub>CC(I/O)</sub> = 3.3 V	130 mA
V <sub>CC</sub> = 3.3 V, V <sub>CC(I/O)</sub> = 3.3 V	117 mA
V <sub>CC</sub> = 5.0 V, V <sub>CC(I/O)</sub> = 1.8 V	122 mA
V <sub>CC</sub> = 3.3 V, V <sub>CC(I/O)</sub> = 1.8 V	117 mA

The idle operating current, I<sub>CC</sub>, that is, when the ISP1760 is in operational mode, initialized and without any devices connected, is 70 mA. The additional current consumption on I<sub>CC</sub> is below 1 mA per port in the case of full-speed and low-speed devices.

Deep-sleep suspend mode ensures the lowest power consumption when V<sub>CC</sub> is always supplied to the ISP1760. The suspend current I<sub>CC(susp)</sub> is typically about 150 μA at room temperature. The suspend current may increase if the ambient temperature increases. For details, see [Section 7.6](#).

In hybrid mode, when V<sub>CC</sub> is disconnected, I<sub>CC(I/O)</sub> will generally be below 100 μA. The average value is 60 μA to 70 μA.

Under the condition of constant read and write accesses occurring on the 32-bit data bus, the maximum I<sub>CC(I/O)</sub> drawn from V<sub>CC(I/O)</sub> is measured as 25 mA when the ST-Ericsson' ISP1760 evaluation board is connected to a BSQUARE PXA255 development platform. This current will vary depending on the platform because of the different access timing, the type of data patterns written on the data bus, and loading on the data bus.

## 11. Limiting values

**Table 86. Limiting values**

In accordance with the Absolute Maximum Rating System (IEC 60134).

Symbol	Parameter	Conditions	Min	Max	Unit
$V_{CC(I/O)}$	input/output supply voltage		-0.5	+4.6	V
$V_{CC(5V0)}$	supply voltage (5.0 V)		-0.5	+5.6	V
$I_{lu}$	latch-up current	$V_I < 0\text{ V}$ or $V_I > V_{CC}$	-	100	mA
$V_{esd}$	electrostatic discharge voltage	$I_{LI} < 1\ \mu\text{A}$ (all pins)	-4000	+4000	V
$T_{stg}$	storage temperature		-40	+125	°C

## 12. Recommended operating conditions

**Table 87. Recommended operating conditions**

Symbol	Parameter	Conditions	Min	Typ	Max	Unit
$V_{CC(I/O)}$	input/output supply voltage	$V_{CC(I/O)} = 3.3\text{ V}$	3.0	3.3	3.6	V
		$V_{CC(I/O)} = 1.8\text{ V}$	1.65	1.8	1.95	V
$V_{CC(5V0)}$	supply voltage (5.0 V)		3.0	-	5.5	V
$T_{amb}$	ambient temperature		-40	-	+85	°C
$I_{CC(susp)}$	suspend supply current	$T_{amb} = 25\text{ °C}$ ; $V_{CC(5V0)} = 3.3\text{ V}$	[1] -	150	-	μA

[1] Deep-sleep suspend mode.

### 13. Static characteristics

**Table 88. Static characteristics: digital pins**

Digital pins: A[17:1], DATA[31:0], CS\_N, RD\_N, WR\_N, DACK, DREQ, IRQ, RESET\_N, SUSPEND/WAKEUP\_N, CLKIN, OC1\_N, OC2\_N, OC3\_N.

OC1\_N, OC2\_N and OC3\_N are used as digital overcurrent pins;  $T_{amb} = -40\text{ °C to }+85\text{ °C}$ ; unless otherwise specified.

Symbol	Parameter	Conditions	Min	Typ	Max	Unit
<b><math>V_{CC(I/O)} = 1.65\text{ V to }1.95\text{ V}</math></b>						
V <sub>IH</sub>	HIGH-level input voltage		1.2	-	-	V
V <sub>IL</sub>	LOW-level input voltage		-	-	0.5	V
V <sub>hys</sub>	hysteresis voltage		0.4	-	0.7	V
V <sub>OL</sub>	LOW-level output voltage	I <sub>OL</sub> = 3 mA	-	-	0.22V <sub>CC(I/O)</sub>	V
V <sub>OH</sub>	HIGH-level output voltage		0.8V <sub>CC(I/O)</sub>	-	-	V
I <sub>LI</sub>	input leakage current	V <sub>I</sub> = 0 V to V <sub>CC(I/O)</sub>	-	-	1	μA
C <sub>in</sub>	input capacitance		-	2.75	-	pF
<b><math>V_{CC(I/O)} = 3.0\text{ V to }3.6\text{ V}</math></b>						
V <sub>IH</sub>	HIGH-level input voltage		2.0	-	-	V
V <sub>IL</sub>	LOW-level input voltage		-	-	0.8	V
V <sub>hys</sub>	hysteresis voltage		0.4	-	0.7	V
V <sub>OL</sub>	LOW-level output voltage	I <sub>OL</sub> = 3 mA	-	-	0.4	V
V <sub>OH</sub>	HIGH-level output voltage		2.4	-	-	V
I <sub>LI</sub>	input leakage current	V <sub>I</sub> = 0 V to V <sub>CC(I/O)</sub>	-	-	1	μA
C <sub>in</sub>	input capacitance		-	2.75	-	pF

**Table 89. Static characteristics: PSW1\_N, PSW2\_N, PSW3\_N**

$V_{CC(I/O)} = 1.65\text{ V to }3.6\text{ V}$ ;  $T_{amb} = -40\text{ °C to }+85\text{ °C}$ ; unless otherwise specified.

Symbol	Parameter	Conditions	Min	Typ	Max	Unit
V <sub>OL</sub>	LOW-level output voltage	I <sub>OL</sub> = 8 mA; pull-up to V <sub>CC(5V0)</sub>	-	-	0.4	V
V <sub>OH</sub>	HIGH-level output voltage	pull-up to V <sub>CC(I/O)</sub>	-	V <sub>CC(I/O)</sub>	-	V

**Table 90. Static characteristics: USB interface block (pins DM1 to DM3 and DP1 to DP3)**

$V_{CC(I/O)} = 1.65\text{ V to }3.6\text{ V}$ ;  $T_{amb} = -40\text{ °C to }+85\text{ °C}$ ; unless otherwise specified.

Symbol	Parameter	Conditions	Min	Typ	Max	Unit
<b>Input levels for high-speed</b>						
V <sub>HSSQ</sub>	high-speed squelch detection threshold voltage (differential signal amplitude)	squelch detected	-	-	100	mV
		no squelch detected	150	-	-	mV
V <sub>HSDSC</sub>	high-speed disconnect detection threshold voltage (differential signal amplitude)	disconnect detected	625	-	-	mV
		disconnect not detected	-	-	525	mV
V <sub>HSCM</sub>	high-speed data signaling common mode voltage range (guideline for receiver)		-50	-	+500	mV
<b>Output levels for high-speed</b>						
V <sub>HSOI</sub>	high-speed idle level		-10	-	+10	mV

**Table 90. Static characteristics: USB interface block (pins DM1 to DM3 and DP1 to DP3) ...continued**

$V_{CC(I/O)} = 1.65\text{ V to }3.6\text{ V}$ ;  $T_{amb} = -40\text{ °C to }+85\text{ °C}$ ; unless otherwise specified.

Symbol	Parameter	Conditions	Min	Typ	Max	Unit
$V_{HSOH}$	high-speed data signaling HIGH-level voltage		360	-	440	mV
$V_{HSOL}$	high-speed data signaling LOW-level voltage		-10	-	+10	mV
$V_{CHIRPJ}$	Chirp J level (differential voltage)		700 <sup>[1]</sup>	-	1100	mV
$V_{CHIRPK}$	Chirp K level (differential voltage)		-900 <sup>[1]</sup>	-	-500	mV
<b>Input levels for full-speed and low-speed</b>						
$V_{IH}$	HIGH-level input voltage		2.0	-	-	V
$V_{IHZ}$	HIGH-level input voltage (floating)		2.7	-	3.6	V
$V_{IL}$	LOW-level input voltage		-	-	0.8	V
$V_{DI}$	differential input sensitivity	$ V_{DP} - V_{DM} $	0.2	-	-	V
$V_{CM}$	differential common mode voltage range		0.8	-	2.5	V
<b>Output levels for full-speed and low-speed</b>						
$V_{OH}$	HIGH-level output voltage		2.8	-	3.6	V
$V_{OL}$	LOW-level output voltage		0	-	0.3	V
$V_{OSE1}$	SE1 output voltage		0.8	-	-	V
$V_{CRS}$	output signal crossover voltage		1.3	-	2.0	V

[1] The HS termination resistor is disabled, and the pull-up resistor is connected. Only during reset, when both the hub and the device are capable of the high-speed operation.

**Table 91. Static characteristics: REF5V**

$V_{CC(I/O)} = 1.65\text{ V to }3.6\text{ V}$ ;  $T_{amb} = -40\text{ °C to }+85\text{ °C}$ ; unless otherwise specified.

Symbol	Parameter	Conditions	Min	Typ	Max	Unit
$V_{IH}$	HIGH-level input voltage		-	5	-	V

### 14. Dynamic characteristics

**Table 92. Dynamic characteristics: system clock timing**

$V_{CC(I/O)} = 1.65\text{ V to }3.6\text{ V}$ ;  $T_{amb} = -40\text{ °C to }+85\text{ °C}$ ; unless otherwise specified.

Symbol	Parameter	Conditions	Min	Typ	Max	Unit
<b>Crystal oscillator</b>						
$f_{clk}$	clock frequency	crystal <sup>[1]</sup>	<sup>[2]</sup> -	12	-	MHz
		oscillator	-	12	-	MHz
<b>External clock input</b>						
$t_j$	external clock jitter		-	-	500	ps
$\delta$	clock duty cycle		-	50	-	%
$V_{i(XTAL1)}$	input voltage on pin XTAL1		-	$V_{CC(I/O)}$	-	V
$t_r$	rise time		-	-	3	ns
$t_f$	fall time		-	-	3	ns

[1] Recommended values for external capacitors when using a crystal are 22 pF to 27 pF.

[2] Recommended accuracy of the clock frequency is 50 ppm for the crystal and oscillator. The oscillator used depends on  $V_{CC(I/O)}$ .

**Table 93. Dynamic characteristics: CPU interface block**

$V_{CC(I/O)} = 1.65\text{ V to }3.6\text{ V}$ ;  $T_{amb} = -40\text{ °C to }+85\text{ °C}$ ; unless otherwise specified.

Symbol	Parameter	Conditions	Min	Typ	Max	Unit
SR	slew rate	standard load	1	-	4	V/ns

**Table 94. Dynamic characteristics: high-speed source electrical characteristics**

$V_{CC(I/O)} = 1.65\text{ V to }3.6\text{ V}$ ;  $T_{amb} = -40\text{ °C to }+85\text{ °C}$ ; unless otherwise specified.

Symbol	Parameter	Conditions	Min	Typ	Max	Unit
<b>Driver characteristics</b>						
$t_{HSR}$	rise time (10 % to 90 %)		500	-	-	ps
$t_{HSF}$	fall time (10 % to 90 %)		500	-	-	ps
$Z_{HSDRV}$	driver output impedance (which also serves as high-speed termination)	includes the $R_S$ resistor	<sup>[1]</sup> 40.5	45	49.5	$\Omega$
<b>Clock timing</b>						
$t_{HSDRAT}$	high-speed data rate		479.76	-	480.24	Mbit/s
$t_{HSFRAM}$	microframe interval		124.9375	-	125.0625	$\mu\text{s}$
$t_{HSRFI}$	consecutive microframe interval difference		1	-	four high-speed bit times	ns

[1] This also serves as a high-speed termination.



**Table 95. Dynamic characteristics: full-speed source electrical characteristics**

$V_{CC(I/O)} = 1.65\text{ V to }3.6\text{ V}$ ;  $T_{amb} = -40\text{ }^{\circ}\text{C to }+85\text{ }^{\circ}\text{C}$ ; unless otherwise specified.

Symbol	Parameter	Conditions	Min	Typ	Max	Unit
<b>Driver characteristics</b>						
$t_{FR}$	rise time	$C_L = 50\text{ pF}$ ; 10 % to 90 % of $ V_{OH} - V_{OL} $	4	-	20	ns
$t_{FF}$	fall time	$C_L = 50\text{ pF}$ ; 90 % to 10 % of $ V_{OH} - V_{OL} $	4	-	20	ns
$t_{FRFM}$	differential rise and fall time matching		90	-	111.1	%
$Z_{DRV}$	driver output impedance	for driver that is not high-speed capable	28	-	44	$\Omega$

**Data timing: see Figure 14**

$t_{FDEOP}$	source jitter for differential transition to SE0 transition	full-speed timing	-2	-	+5	ns
$t_{FEOPT}$	source SE0 interval of EOP		160	-	175	ns
$t_{FEOPR}$	receiver SE0 interval of EOP		82	-	-	ns
$t_{LDEOP}$	upstream facing port source jitter for differential transition to SE0 transition	low-speed timing	-40	-	+100	ns
$t_{LEOPT}$	source SE0 interval of EOP		1.25	-	1.5	$\mu\text{s}$
$t_{LEOPR}$	receiver SE0 interval of EOP		670	-	-	ns
$t_{FST}$	width of SE0 interval during differential transition		-	-	14	ns

**Table 96. Dynamic characteristics: low-speed source electrical characteristics**

$V_{CC(I/O)} = 1.65\text{ V to }3.6\text{ V}$ ;  $T_{amb} = -40\text{ }^{\circ}\text{C to }+85\text{ }^{\circ}\text{C}$ ; unless otherwise specified.

Symbol	Parameter	Conditions	Min	Typ	Max	Unit
<b>Driver characteristics</b>						
$t_{LR}$	transition time: rise time		75	-	300	ns
$t_{LF}$	transition time: fall time		75	-	300	ns
$t_{LRFM}$	rise and fall time matching		90	-	125	%

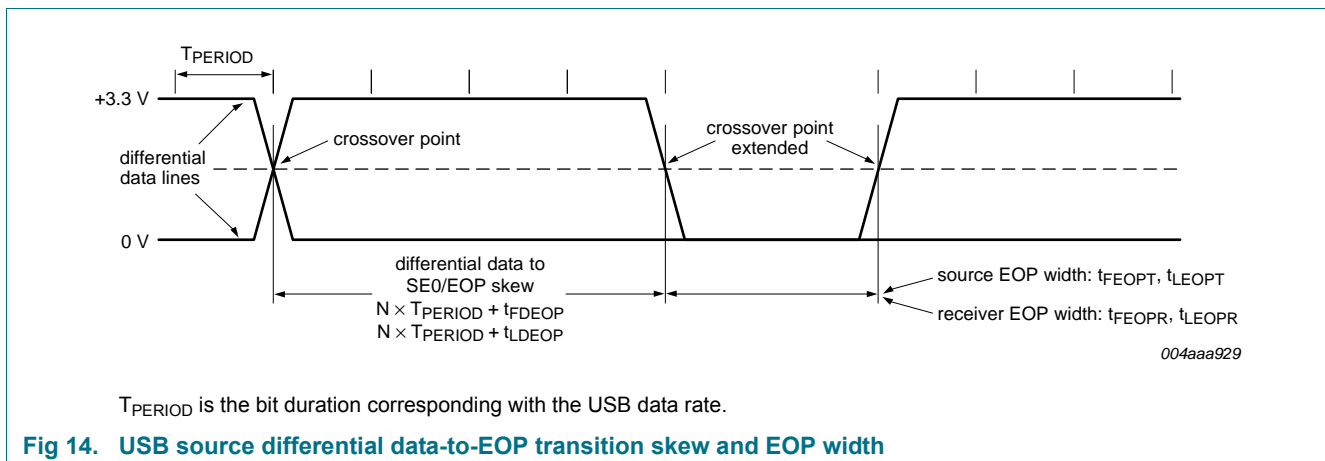

**Fig 14. USB source differential data-to-EOP transition skew and EOP width**

### 14.1 PIO timing

#### 14.1.1 Register or memory write

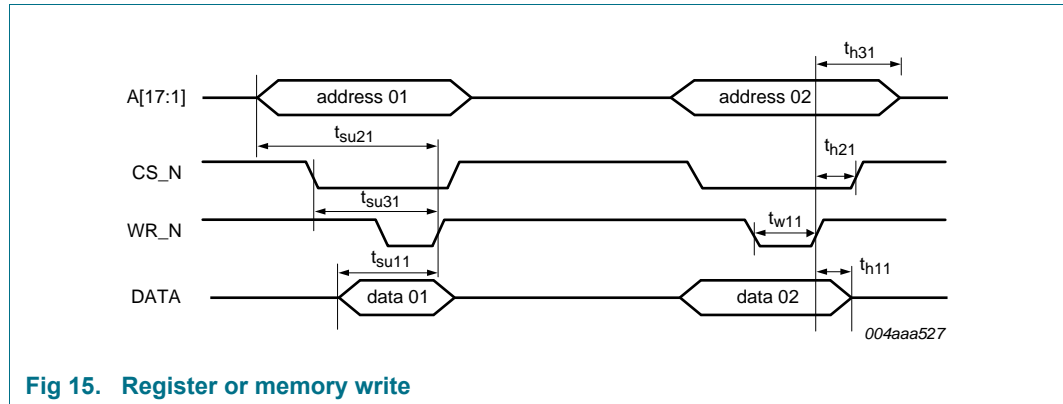

**Fig 15. Register or memory write**

**Table 97. Register or memory write**

$T_{amb} = -40\text{ }^{\circ}\text{C to }+85\text{ }^{\circ}\text{C}$ ; unless otherwise specified.

Symbol	Parameter	Min	Max	Unit
<b><math>V_{CC(I/O)} = 1.65\text{ V to }1.95\text{ V}</math></b>				
$t_{h11}$	data hold after WR_N HIGH	2	-	ns
$t_{h21}$	CS_N hold after WR_N HIGH	1	-	ns
$t_{h31}$	address hold after WR_N HIGH	2	-	ns
$t_w11$	WR_N pulse width	17	-	ns
$t_{su11}$	data set-up time before WR_N HIGH	5	-	ns
$t_{su21}$	address set-up time before WR_N HIGH	5	-	ns
$t_{su31}$	CS_N set-up time before WR_N HIGH	5	-	ns
<b><math>V_{CC(I/O)} = 3.3\text{ V to }3.6\text{ V}</math></b>				
$t_{h11}$	data hold after WR_N HIGH	2	-	ns
$t_{h21}$	CS_N hold after WR_N HIGH	1	-	ns
$t_{h31}$	address hold after WR_N HIGH	2	-	ns
$t_w11$	WR_N pulse width	17	-	ns
$t_{su11}$	data set-up time before WR_N HIGH	5	-	ns
$t_{su21}$	address set-up time before WR_N HIGH	5	-	ns
$t_{su31}$	CS_N set-up time before WR_N HIGH	5	-	ns

### 14.1.2 Register read

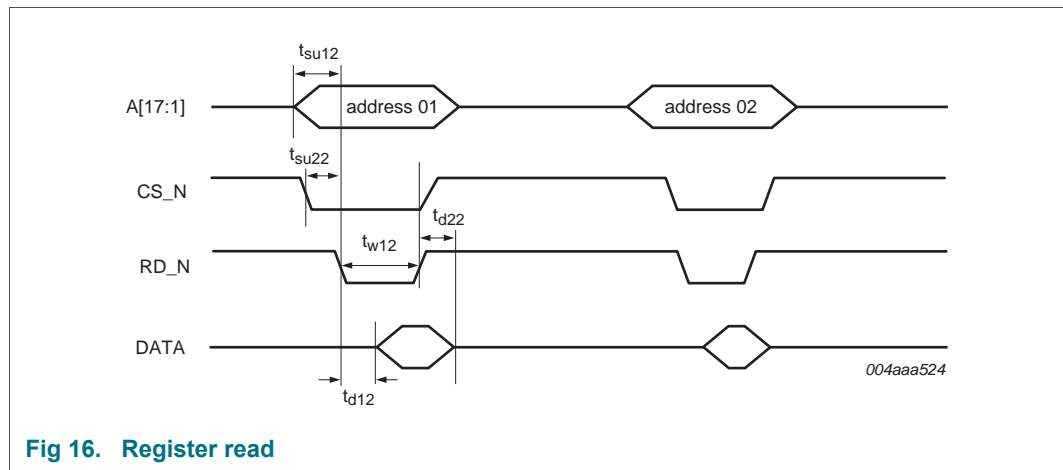

**Fig 16. Register read**

**Table 98. Register read**

$T_{amb} = -40\text{ }^{\circ}\text{C to }+85\text{ }^{\circ}\text{C}$ ; unless otherwise specified.

Symbol	Parameter	Min	Max	Unit
<b><math>V_{CC(I/O)} = 1.65\text{ V to }1.95\text{ V}</math></b>				
$t_{su12}$	address set-up time before RD_N LOW	0	-	ns
$t_{su22}$	CS_N set-up time before RD_N LOW	0	-	ns
$t_{w12}$	RD_N pulse width	$> t_{d12}$	-	ns
$t_{d12}$	data valid time after RD_N LOW	-	35	ns
$t_{d22}$	data valid time after RD_N HIGH	-	1	ns
<b><math>V_{CC(I/O)} = 3.3\text{ V to }3.6\text{ V}</math></b>				
$t_{su12}$	address set-up time before RD_N LOW	0	-	ns
$t_{su22}$	CS_N set-up time before RD_N LOW	0	-	ns
$t_{w12}$	RD_N pulse width	$> t_{d12}$	-	ns
$t_{d12}$	data valid time after RD_N LOW	-	22	ns
$t_{d22}$	data valid time after RD_N HIGH	-	1	ns

### 14.1.3 Register access

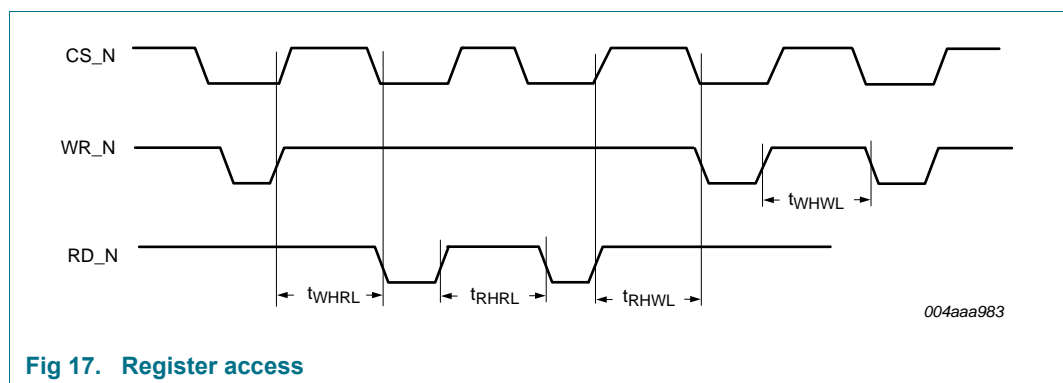

**Fig 17. Register access**

**Table 99. Register access**

$T_{amb} = -40\text{ }^{\circ}\text{C}$  to  $+85\text{ }^{\circ}\text{C}$ ; unless otherwise specified.

Symbol	Parameter	Min	Max	Unit
$t_{WHRL}$	WR_N HIGH to RD_N LOW time	25 <sup>[1]</sup>	-	ns
$t_{RHRL}$	RD_N HIGH to RD_N LOW time	25 <sup>[1]</sup>	-	ns
$t_{RHWL}$	RD_N HIGH to WR_N LOW time	25	-	ns
$t_{WHWL}$	WR_N HIGH to WR_N LOW time	25 <sup>[1]</sup>	-	ns

[1] For EHCI operational registers, minimum value is 195 ns.

### 14.1.4 Memory read

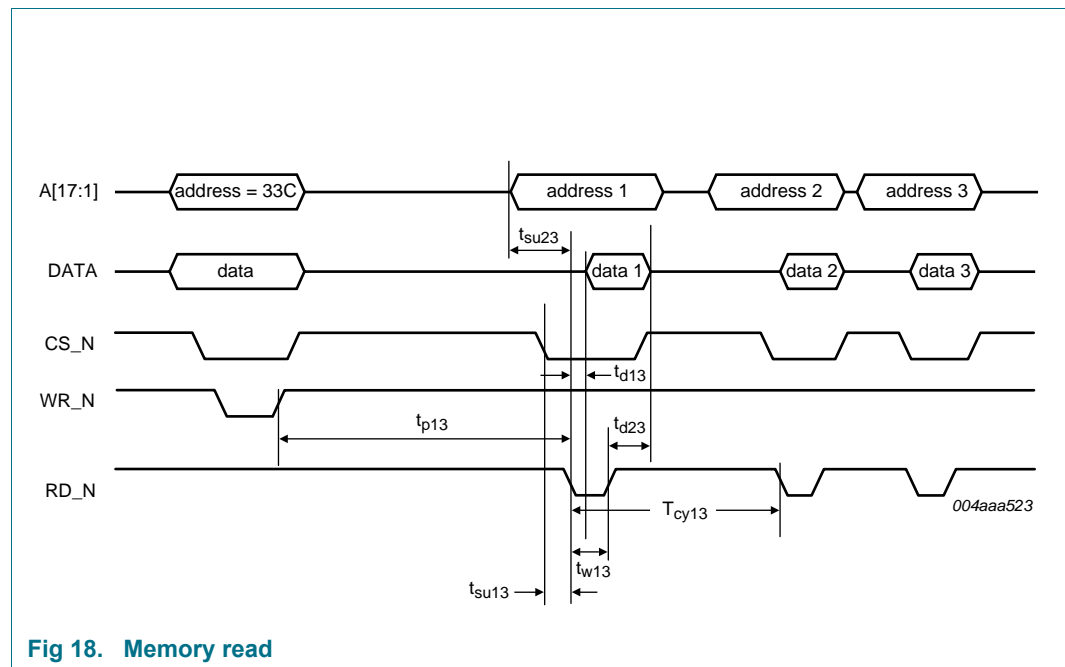

**Fig 18. Memory read**

**Table 100. Memory read**

$T_{amb} = -40\text{ }^{\circ}\text{C}$  to  $+85\text{ }^{\circ}\text{C}$ ; unless otherwise specified.

Symbol	Parameter	Min	Max	Unit
<b><math>V_{CC(I/O)} = 1.65\text{ V to }1.95\text{ V}</math></b>				
$t_{p13}$	initial pre-fetch time	90	-	ns
$T_{cy13}$	memory RD_N cycle time	40	-	ns
$t_{d13}$	data valid time after RD_N LOW	-	31	ns
$t_{d23}$	data available time after RD_N HIGH	-	1	ns
$t_{w13}$	RD_N pulse width	32	-	ns
$t_{su13}$	CS_N set-up time before RD_N LOW	0	-	ns
$t_{su23}$	address set-up time before RD_N LOW	0	-	ns
<b><math>V_{CC(I/O)} = 3.3\text{ V to }3.6\text{ V}</math></b>				
$t_{p13}$	initial pre-fetch time	90	-	ns
$T_{cy13}$	memory RD_N cycle time	36	-	ns
$t_{d13}$	data valid time after RD_N LOW	-	20	ns

**Table 100. Memory read ...continued**

$T_{amb} = -40\text{ }^{\circ}\text{C to }+85\text{ }^{\circ}\text{C}$ ; unless otherwise specified.

Symbol	Parameter	Min	Max	Unit
$t_{d23}$	data available time after RD_N HIGH	-	1	ns
$t_{w13}$	RD_N pulse width	21	-	ns
$t_{su13}$	CS_N set-up time before RD_N LOW	0	-	ns
$t_{su23}$	address set-up time before RD_N LOW	0	-	ns

## 14.2 DMA timing

In the following sections:

- Polarity of DACK is active HIGH
- Polarity of DREQ is active HIGH.

### 14.2.1 Single cycle: DMA read

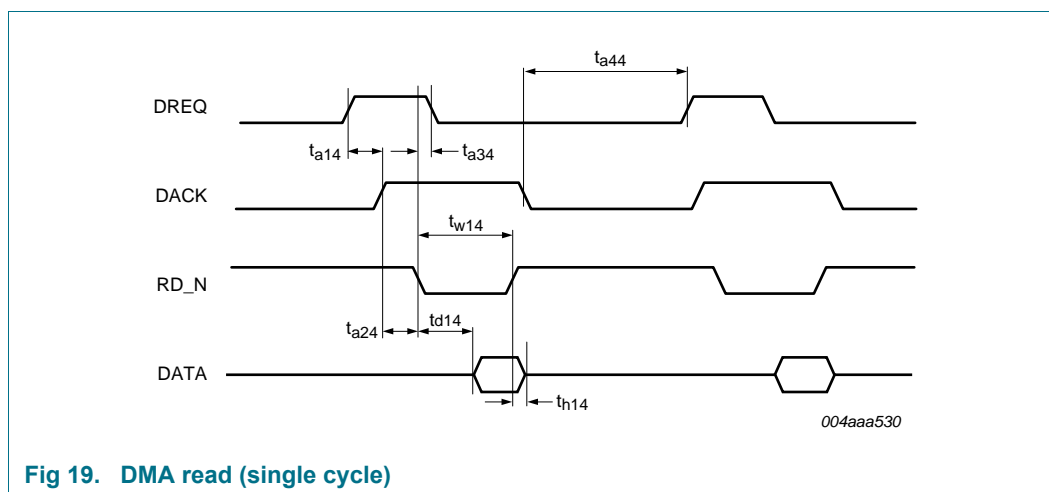

**Fig 19. DMA read (single cycle)**

**Table 101. DMA read (single cycle)**

$T_{amb} = -40\text{ }^{\circ}\text{C to }+85\text{ }^{\circ}\text{C}$ ; unless otherwise specified.

Symbol	Parameter	Min	Max	Unit
<b><math>V_{CC(I/O)} = 1.65\text{ V to }1.95\text{ V}</math></b>				
$t_{a14}$	DACK assertion time after DREQ assertion	0	-	ns
$t_{a24}$	RD_N assertion time after DACK assertion	0	-	ns
$t_{d14}$	data valid time after RD_N assertion	-	24	ns
$t_{w14}$	RD_N pulse width	$> t_{d14}$	-	ns
$t_{a34}$	DREQ de-assertion time after RD_N assertion	-	29	ns
$t_{a44}$	DACK de-assertion to next DREQ assertion time	-	56	ns
$t_{h14}$	data hold time after RD_N de-asserts	-	5	ns
<b><math>V_{CC(I/O)} = 3.3\text{ V to }3.6\text{ V}</math></b>				
$t_{a14}$	DACK assertion time after DREQ assertion	0	-	ns
$t_{a24}$	RD_N assertion time after DACK assertion	0	-	ns
$t_{d14}$	data valid time after RD_N assertion	-	20	ns

**Table 101. DMA read (single cycle) ...continued**  
 $T_{amb} = -40\text{ }^{\circ}\text{C to } +85\text{ }^{\circ}\text{C}$ ; unless otherwise specified.

Symbol	Parameter	Min	Max	Unit
$t_{w14}$	RD_N pulse width	$> t_{d14}$	-	ns
$t_{a34}$	DREQ de-assertion time after RD_N assertion	-	18	ns
$t_{a44}$	DACK de-assertion to next DREQ assertion time	-	56	ns
$t_{h14}$	data hold time after RD_N de-asserts	-	5	ns

### 14.2.2 Single cycle: DMA write

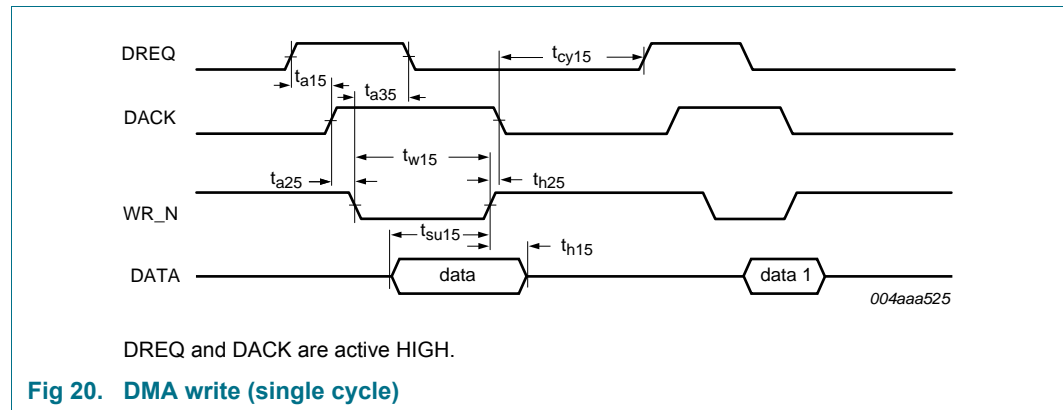

**Table 102. DMA write (single cycle)**  
 $T_{amb} = -40\text{ }^{\circ}\text{C to } +85\text{ }^{\circ}\text{C}$ ; unless otherwise specified.

Symbol	Parameter	Min	Max	Unit
<b><math>V_{CC(I/O)} = 1.65\text{ V to } 1.95\text{ V}</math></b>				
$t_{a15}$	DACK assertion time after DREQ assertion	0	-	ns
$t_{a25}$	WR_N assertion time after DACK assertion	1	-	ns
$t_{h15}$	data hold time after WR_N de-assertion	3	-	ns
$t_{h25}$	DACK hold time after WR_N de-assertion	0	-	ns
$t_{su15}$	data set-up time before WR_N de-assertion	5.5	-	ns
$t_{a35}$	DREQ de-assertion time after WR_N assertion	-	28	ns
$t_{cy15}$	last DACK strobe de-assertion to next DREQ assertion time	-	82	ns
$t_{w15}$	WR_N pulse width	22	-	ns
<b><math>V_{CC(I/O)} = 3.3\text{ V to } 3.6\text{ V}</math></b>				
$t_{a15}$	DACK assertion time after DREQ assertion	0	-	ns
$t_{a25}$	WR_N assertion time after DACK assertion	1	-	ns
$t_{h15}$	data hold time after WR_N de-assertion	2	-	ns
$t_{h25}$	DACK hold time after WR_N de-assertion	0	-	ns
$t_{su15}$	data set-up time before WR_N de-assertion	5.5	-	ns
$t_{a35}$	DREQ de-assertion time after WR_N assertion	-	16	ns
$t_{cy15}$	last DACK strobe de-assertion to next DREQ assertion time	-	82	ns
$t_{w15}$	WR_N pulse width	22	-	ns

### 14.2.3 Multi-cycle: DMA read

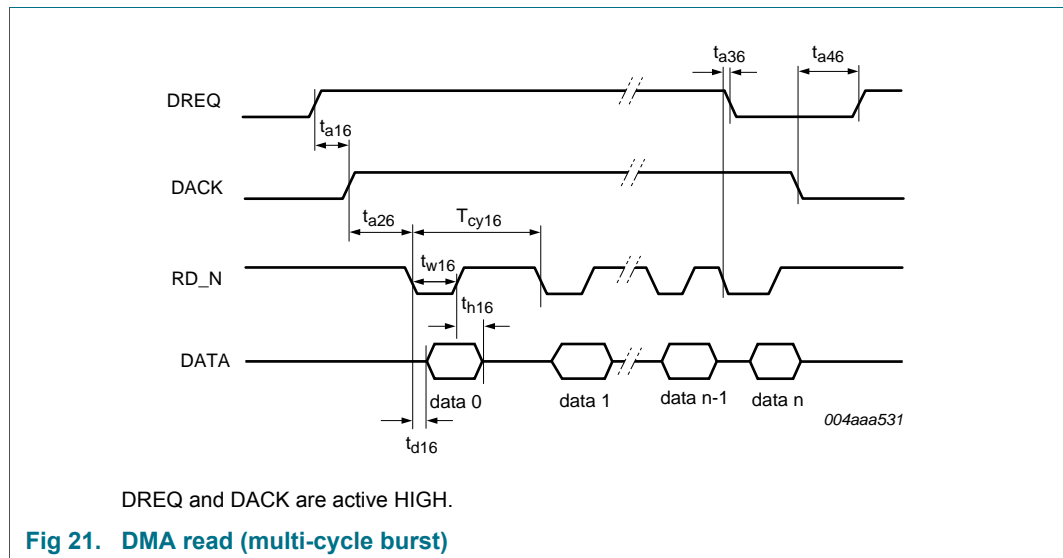

**Table 103. DMA read (multi-cycle burst)**

$T_{amb} = -40\text{ }^{\circ}\text{C to }+85\text{ }^{\circ}\text{C}$ ; unless otherwise specified.

Symbol	Parameter	Min	Max	Unit
<b><math>V_{CC(I/O)} = 1.65\text{ V to }1.95\text{ V}</math></b>				
$t_{a16}$	DACK assertion after DREQ assertion time	0	-	ns
$t_{a26}$	RD_N assertion after DACK assertion time	0	-	ns
$t_{d16}$	data valid time after RD_N assertion	-	31	ns
$t_{w16}$	RD_N pulse width	38	-	ns
$T_{cy16}$	read-to-read cycle time	46	-	ns
$t_{a36}$	DREQ de-assertion time after last burst RD_N de-assertion	-	30	ns
$t_{a46}$	DACK de-assertion to next DREQ assertion time	-	82	ns
$t_{h16}$	data hold time after RD_N de-asserts	-	5	ns
<b><math>V_{CC(I/O)} = 3.3\text{ V to }3.6\text{ V}</math></b>				
$t_{a16}$	DACK assertion after DREQ assertion time	0	-	ns
$t_{a26}$	RD_N assertion after DACK assertion time	0	-	ns
$t_{d16}$	data valid time after RD_N assertion	-	16	ns
$t_{w16}$	RD_N pulse width	17	-	ns
$T_{cy16}$	read-to-read cycle time	38	-	ns
$t_{a36}$	DREQ de-assertion time after last burst RD_N de-assertion	-	20	ns
$t_{a46}$	DACK de-assertion to next DREQ assertion time	-	82	ns
$t_{h16}$	data hold time after RD_N de-asserts	-	5	ns

### 14.2.4 Multi-cycle: DMA write

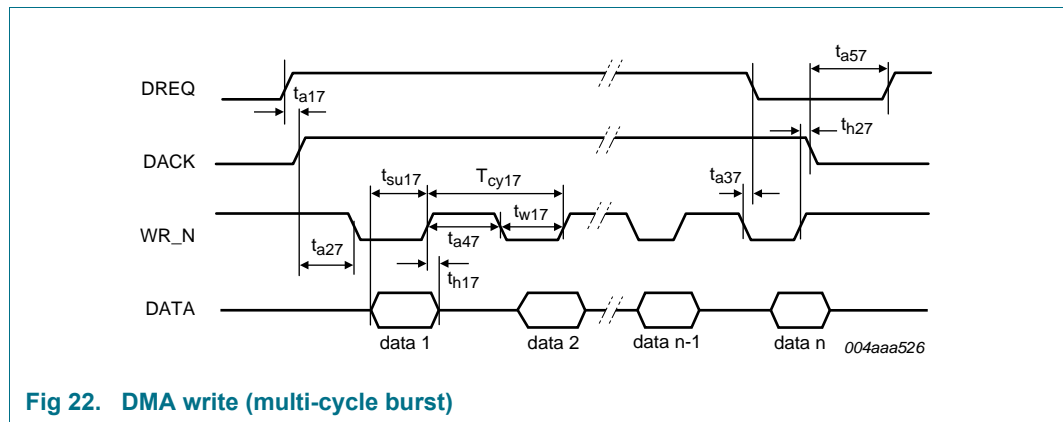

Fig 22. DMA write (multi-cycle burst)

Table 104. DMA write (multi-cycle burst)

$T_{amb} = -40\text{ }^{\circ}\text{C to }+85\text{ }^{\circ}\text{C}$ ; unless otherwise specified.

Symbol	Parameter	Min	Max	Unit
<b><math>V_{CC(I/O)} = 1.65\text{ V to }1.95\text{ V}</math></b>				
$T_{cy17}$	DMA write cycle time	51	-	ns
$t_{su17}$	data set-up time before WR_N de-assertion	5	-	ns
$t_{h17}$	data hold time after WR_N de-assertion	2	-	ns
$t_{a17}$	DACK assertion time after DREQ assertion	0	-	ns
$t_{a27}$	WR_N assertion time after DACK assertion	2	-	ns
$t_{a37}$	DREQ de-assertion time at last strobe (WR_N) assertion	-	28	ns
$t_{h27}$	DACK hold time after WR_N de-assertion	0	-	ns
$t_{a47}$	strobe de-assertion to next strobe assertion time	34	-	ns
$t_{w17}$	WR_N pulse width	17	-	ns
$t_{a57}$	DACK de-assertion to next DREQ assertion time	-	82	ns
<b><math>V_{CC(I/O)} = 3.3\text{ V to }3.6\text{ V}</math></b>				
$T_{cy17}$	DMA write cycle time	51	-	ns
$t_{su17}$	data set-up time before WR_N de-assertion	5	-	ns
$t_{h17}$	data hold time after WR_N de-assertion	2	-	ns
$t_{a17}$	DACK assertion time after DREQ assertion	0	-	ns
$t_{a27}$	WR_N assertion time after DACK assertion	1	-	ns
$t_{a37}$	DREQ de-assertion time at last strobe (WR_N) assertion	-	16	ns
$t_{h27}$	DACK hold time after WR_N de-assertion	0	-	ns
$t_{a47}$	strobe de-assertion to next strobe assertion time	34	-	ns
$t_{w17}$	WR_N pulse width	17	-	ns
$t_{a57}$	DACK de-assertion to next DREQ assertion time	-	82	ns



## 15. Package outline

LQFP128: plastic low profile quad flat package; 128 leads; body 14 x 20 x 1.4 mm

SOT425-1

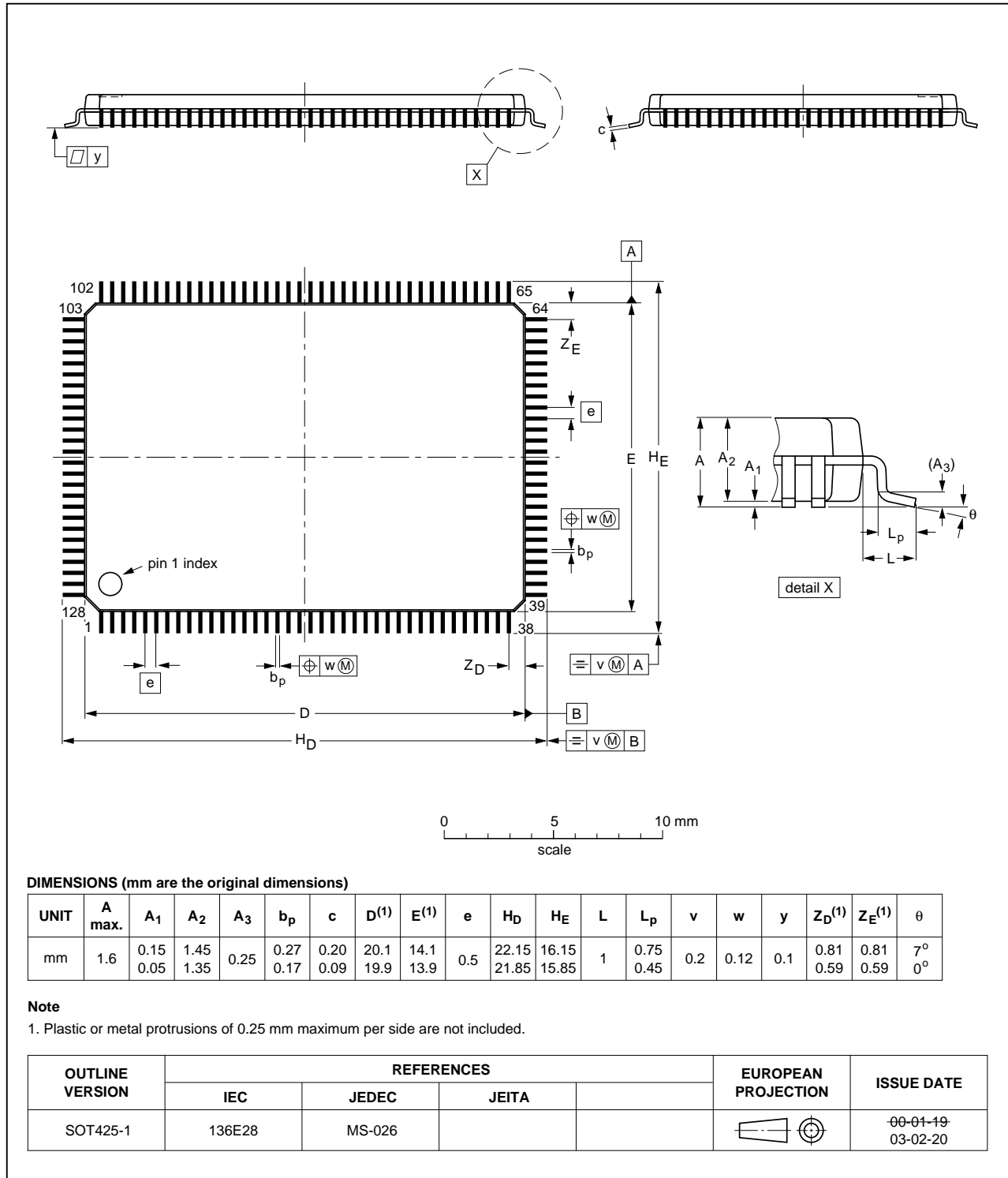

Fig 23. Package outline SOT425-1 (LQFP128)

TFBGA128: plastic thin fine-pitch ball grid array package; 128 balls; body 9 x 9 x 0.8 mm

SOT857-1

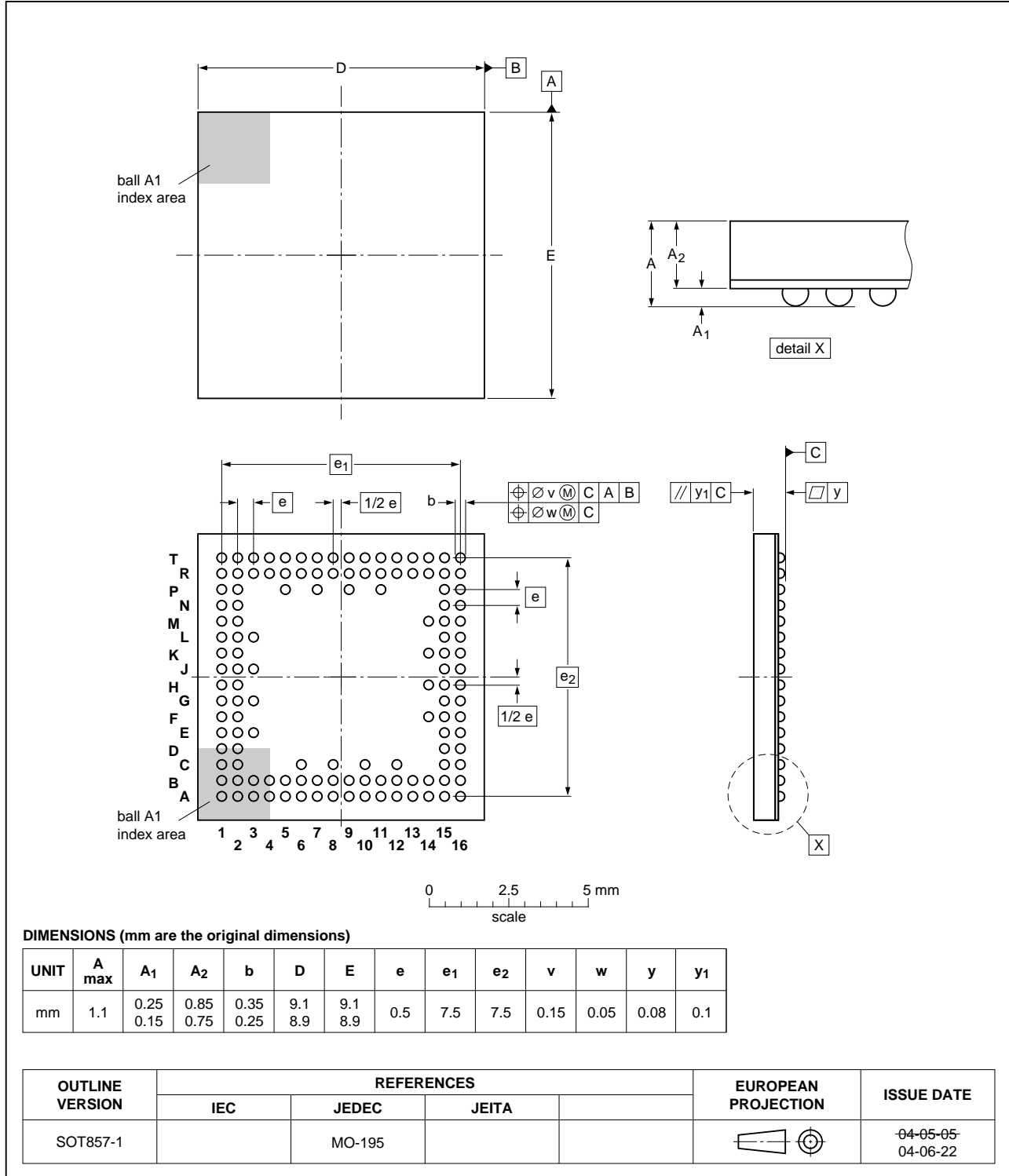

Fig 24. Package outline SOT857-1 (TFBGA128)

## 16. Abbreviations

**Table 105. Abbreviations**

Acronym	Description
ACK	Acknowledgment
ASIC	Application-Specific Integrated Circuit
ATL	Asynchronous Transfer List
ATX	Analog Transceiver
CS	Complete Split
DMA	Direct Memory Access
DW	Double Word
EHCI	Enhanced Host Controller Interface
EMI	ElectroMagnetic Interference
EOP	End-Of-Packet
EOS	Electrical OverStress
EOT	End-Of-Transfer
ESD	ElectroStatic Discharge
ESR	Effective Series Resistance
FIFO	First In, First Out
FLS	Frame List Size
FS	Full-Speed
GPIO	General-Purpose Input/Output
HC	Host Controller
HNP	Host Negotiation Protocol
HS	High-Speed
iTD	isochronous Transfer Descriptor
INT	Interrupt
ISO	Isochronous
ISR	Interrupt Service Routine
ITL	Isochronous (ISO) Transfer List
LS	Low-Speed
NAK	Not Acknowledged
NYET	Not Yet
OC	Overcurrent
OHCI	Open Host Controller Interface
PCI	Peripheral Component Interconnect
PDA	Personal Digital Assistant
PID	Packer Identifier
PIO	Programmed Input/Output
PLL	Phase-Locked Loop
PMOS	Positive-channel Metal-Oxide Semiconductor
POR	Power-On Reset
PORP	Power-On Reset Pulse

**Table 105. Abbreviations** ...continued

Acronym	Description
PTD	Proprietary Transfer Descriptor
RISC	Reduced Instruction Set Computer
SE0	Single Ended 0
SE1	Single Ended 1
siTD	split isochronous Transfer Descriptor
SOF	Start-Of-Frame
SRP	Session Request Protocol
SS	Start Split
TT	Transaction Translator
UHCI	Universal Host Controller Interface
USB	Universal Serial Bus

## 17. References

- [1] Universal Serial Bus Specification Rev. 2.0
- [2] Enhanced Host Controller Interface Specification for Universal Serial Bus Rev. 1.0
- [3] Embedded Systems Design with the ISP176x (AN10043)
- [4] ISP176x Linux Programming Gui13de (AN10042)
- [5] Interfacing the ISP176x to the Intel PXA25x processor (AN10037)

## 18. Revision history

**Table 106. Revision history**

Document ID	Release date	Data sheet status	Change notice	Supersedes
ISP1760_7	20091130	Product data sheet	-	ISP1760_6
Modifications:	<ul style="list-style-type: none"> <li>• <a href="#">Table 1 “Ordering information”</a>: updated.</li> <li>• <a href="#">Table 8 “Register overview”</a>: updated.</li> <li>• <a href="#">Table 39 “SW Reset - Software Reset register (address 030Ch) bit description”</a>: updated bit 1 description.</li> <li>• <a href="#">Section 8.3.9 “Force Hub Configuration register”</a>: added.</li> <li>• <a href="#">Section 8.3.10 “Force Port Enable register”</a>: added.</li> </ul>			
ISP1760_6	20090812	Product data sheet	-	ISP1760_5
ISP1760_5	20090122	Product data sheet	-	ISP1760_4
ISP1760_4	20080204	Product data sheet	-	ISP1760_3
ISP1760_3	20070302	Product data sheet	-	ISP1760_2
ISP1760_2 (9397 750 15189)	20051025	Product data sheet	-	ISP1760_1
ISP1760_1 (9397 750 13257)	20041108	Product data sheet	-	-

### 19. Tables

Table 1.	Ordering information	3	Table 26.	ISO PTD Skip Map register (address 0134h) bit description	38
Table 2.	Pin description	6	Table 27.	ISO PTD Last PTD register (address 0138h) bit description	38
Table 3.	Port connection scenarios	15	Table 28.	INT PTD Done Map register (address 0140h) bit description	38
Table 4.	Memory address	17	Table 29.	INT PTD Skip Map register (address 0144h) bit description	38
Table 5.	Using the IRQ Mask AND or IRQ Mask OR registers	23	Table 30.	INT PTD Last PTD register (address 0148h) bit description	39
Table 6.	Hybrid mode	27	Table 31.	ATL PTD Done Map register (address 0150h) bit description	39
Table 7.	Pin status in hybrid mode	27	Table 32.	ATL PTD Skip Map register (address 0154h) bit description	39
Table 8.	Register overview	29	Table 33.	ATL PTD Last PTD register (address 0158h) bit description	40
Table 9.	CAPLENGTH - Capability Length register (address 0000h) bit description	30	Table 34.	HW Mode Control - Hardware Mode Control register (address 0300h) bit allocation	40
Table 10.	HCIVERSION - Host Controller Interface Version Number register (address 0002h) bit description	30	Table 35.	HW Mode Control - Hardware Mode Control register (address 0300h) bit description	41
Table 11.	HCSPARAMS - Host Controller Structural Parameters register (address 0004h) bit allocation	30	Table 36.	Chip ID - Chip Identifier register (address 0304h) bit description	41
Table 12.	HCSPARAMS - Host Controller Structural Parameters register (address 0004h) bit description	31	Table 37.	Scratch register (address 0308h) bit description	42
Table 13.	HCCPARAMS - Host Controller Capability Parameters register (address 0008h) bit allocation	31	Table 38.	SW Reset - Software Reset register (address 030Ch) bit allocation	42
Table 14.	HCCPARAMS - Host Controller Capability Parameters register (address 0008h) bit description	32	Table 39.	SW Reset - Software Reset register (address 030Ch) bit description	42
Table 15.	USBCMD - USB Command register (address 0020h) bit allocation	33	Table 40.	DMA Configuration register (address 0330h) bit allocation	43
Table 16.	USBCMD - USB Command register (address 0020h) bit description	33	Table 41.	DMA Configuration register (address 0330h) bit description	43
Table 17.	USBSTS - USB Status register (address 0024h) bit allocation	33	Table 42.	Buffer Status register (address 0334h) bit allocation	44
Table 18.	USBSTS - USB Status register (address 0024h) bit description	34	Table 43.	Buffer Status register (address 0334h) bit description	44
Table 19.	FRINDEX - Frame Index register (address: 002Ch) bit allocation	34	Table 44.	ATL Done Timeout register (address 0338h) bit description	45
Table 20.	FRINDEX - Frame Index register (address: 002Ch) bit description	35	Table 45.	Memory register (address 033Ch) bit allocation	45
Table 21.	CONFIGFLAG - Configure Flag register (address 0060h) bit allocation	35	Table 46.	Memory register (address 033Ch) bit description	46
Table 22.	CONFIGFLAG - Configure Flag register (address 0060h) bit description	36	Table 47.	Force Hub Configuration register (address 0014h) bit allocation	46
Table 23.	PORTSC1 - Port Status and Control 1 register (address 0064h) bit allocation	36	Table 48.	Force Hub Configuration register (address 0014h) bit description	46
Table 24.	PORTSC1 - Port Status and Control 1 register (address 0064h) bit description	37	Table 49.	Force Port Enable register (address 0018h) bit allocation	47
Table 25.	ISO PTD Done Map register (address 0130h) bit description	37			

[continued >>](#)

Table 50. Force Port Enable register (address 0018h) bit description . . . . .	47	allocation . . . . .	80
Table 51. Edge Interrupt Count register (address 0340h) bit allocation . . . . .	48	Table 82. Start and complete split for interrupt: bit description . . . . .	81
Table 52. Edge Interrupt Count register (address 0340h) bit description . . . . .	48	Table 83. Microframe description . . . . .	83
Table 53. DMA Start Address register (address 0344h) bit allocation . . . . .	48	Table 84. SE description . . . . .	83
Table 54. DMA Start Address register (address 0344h) bit description . . . . .	49	Table 85. Power consumption . . . . .	84
Table 55. Power Down Control register (address 0354h) bit allocation . . . . .	49	Table 86. Limiting values . . . . .	85
Table 56. Power Down Control register (address 0354h) bit description . . . . .	50	Table 87. Recommended operating conditions . . . . .	85
Table 57. Port 1 Control register (address 0374h) bit allocation . . . . .	51	Table 88. Static characteristics: digital pins . . . . .	86
Table 58. Port 1 Control register (address 0374h) bit description . . . . .	52	Table 89. Static characteristics: PSW1_N, PSW2_N, PSW3_N . . . . .	86
Table 59. Interrupt register (address 0310h) bit allocation . . . . .	52	Table 90. Static characteristics: USB interface block (pins DM1 to DM3 and DP1 to DP3) . . . . .	86
Table 60. Interrupt register (address 0310h) bit description . . . . .	53	Table 91. Static characteristics: REF5V . . . . .	87
Table 61. Interrupt Enable register (address 0314h) bit allocation . . . . .	54	Table 92. Dynamic characteristics: system clock timing . . . . .	88
Table 62. Interrupt Enable register (address 0314h) bit description . . . . .	55	Table 93. Dynamic characteristics: CPU interface block . . . . .	88
Table 63. ISO IRQ Mask OR register (address 0318h) bit description . . . . .	56	Table 94. Dynamic characteristics: high-speed source electrical characteristics . . . . .	88
Table 64. INT IRQ Mask OR register (address 031Ch) bit description . . . . .	56	Table 95. Dynamic characteristics: full-speed source electrical characteristics . . . . .	89
Table 65. ATL IRQ Mask OR register (address 0320h) bit description . . . . .	56	Table 96. Dynamic characteristics: low-speed source electrical characteristics . . . . .	89
Table 66. ISO IRQ Mask AND register (address 0324h) bit description . . . . .	56	Table 97. Register or memory write . . . . .	90
Table 67. INT IRQ Mask AND register (address 0328h) bit description . . . . .	57	Table 98. Register read . . . . .	91
Table 68. ATL IRQ Mask AND register (address 032Ch) bit description . . . . .	57	Table 99. Register access . . . . .	92
Table 69. High-speed bulk IN and OUT: bit allocation . . . . .	60	Table 100. Memory read . . . . .	92
Table 70. High-speed bulk IN and OUT: bit description . . . . .	61	Table 101. DMA read (single cycle) . . . . .	93
Table 71. High-speed isochronous IN and OUT: bit allocation . . . . .	64	Table 102. DMA write (single cycle) . . . . .	94
Table 72. High-speed isochronous IN and OUT: bit description . . . . .	65	Table 103. DMA read (multi-cycle burst) . . . . .	95
Table 73. High-speed interrupt IN and OUT: bit allocation . . . . .	68	Table 104. DMA write (multi-cycle burst) . . . . .	96
Table 74. High-speed interrupt IN and OUT: bit description . . . . .	69	Table 105. Abbreviations . . . . .	99
Table 75. Microframe description . . . . .	71	Table 106. Revision history . . . . .	101
Table 76. Start and complete split for bulk: bit allocation . . . . .	72		
Table 77. Start and complete split for bulk: bit description . . . . .	73		
Table 78. SE description . . . . .	75		
Table 79. Start and complete split for isochronous: bit allocation . . . . .	76		
Table 80. Start and complete split for isochronous: bit description . . . . .	77		
Table 81. Start and complete split for interrupt: bit			

## 20. Figures

Fig 1.	Block diagram	4
Fig 2.	Pin configuration (LQFP128); top view	5
Fig 3.	Pin configuration (TFBGA128); top view	5
Fig 4.	Internal hub	14
Fig 5.	ISP1760 clock scheme	14
Fig 6.	Memory segmentation and access block diagram	17
Fig 7.	Adjusting analog overcurrent detection limit (optional) and EOS protection	25
Fig 8.	ISP1760 power supply connection	26
Fig 9.	Most commonly used power supply connection	26
Fig 10.	Hybrid mode	27
Fig 11.	Internal power-on reset timing	28
Fig 12.	Clock with respect to the external power-on reset	28
Fig 13.	NextPTD traversal rule	59
Fig 14.	USB source differential data-to-EOP transition skew and EOP width	89
Fig 15.	Register or memory write	90
Fig 16.	Register read	91
Fig 17.	Register access	91
Fig 18.	Memory read	92
Fig 19.	DMA read (single cycle)	93
Fig 20.	DMA write (single cycle)	94
Fig 21.	DMA read (multi-cycle burst)	95
Fig 22.	DMA write (multi-cycle burst)	96
Fig 23.	Package outline SOT425-1 (LQFP128)	97
Fig 24.	Package outline SOT857-1 (TFBGA128)	98



## 21. Contents

<b>1</b>	<b>General description</b> . . . . .	<b>1</b>	8.3	Configuration registers . . . . .	<b>40</b>
<b>2</b>	<b>Features</b> . . . . .	<b>1</b>	8.3.1	HW Mode Control register . . . . .	<b>40</b>
<b>3</b>	<b>Applications</b> . . . . .	<b>2</b>	8.3.2	Chip ID register . . . . .	<b>41</b>
3.1	Examples of a multitude of possible applications . . . . .	<b>2</b>	8.3.3	Scratch register . . . . .	<b>42</b>
<b>4</b>	<b>Ordering information</b> . . . . .	<b>3</b>	8.3.4	SW Reset register . . . . .	<b>42</b>
<b>5</b>	<b>Block diagram</b> . . . . .	<b>4</b>	8.3.5	DMA Configuration register . . . . .	<b>42</b>
<b>6</b>	<b>Pinning information</b> . . . . .	<b>5</b>	8.3.6	Buffer Status register . . . . .	<b>44</b>
6.1	Pinning . . . . .	<b>5</b>	8.3.7	ATL Done Timeout register . . . . .	<b>45</b>
6.2	Pin description . . . . .	<b>6</b>	8.3.8	Memory register . . . . .	<b>45</b>
<b>7</b>	<b>Functional description</b> . . . . .	<b>13</b>	8.3.9	Force Hub Configuration register . . . . .	<b>46</b>
7.1	ISP1760 internal architecture: advanced ST-Ericsson slave host controller and hub . . . . .	<b>13</b>	8.3.10	Force Port Enable register . . . . .	<b>46</b>
7.1.1	Internal clock scheme and port selection . . . . .	<b>14</b>	8.3.11	Edge Interrupt Count register . . . . .	<b>47</b>
7.2	Host controller buffer memory block . . . . .	<b>15</b>	8.3.12	DMA Start Address register . . . . .	<b>48</b>
7.2.1	General considerations . . . . .	<b>15</b>	8.3.13	Power Down Control register . . . . .	<b>49</b>
7.2.2	Structure of the ISP1760 host controller memory . . . . .	<b>16</b>	8.3.14	Port 1 Control register . . . . .	<b>51</b>
7.3	Accessing the ISP1760 host controller memory: PIO and DMA . . . . .	<b>18</b>	8.4	Interrupt registers . . . . .	<b>52</b>
7.3.1	PIO mode access, memory read cycle . . . . .	<b>18</b>	8.4.1	Interrupt register . . . . .	<b>52</b>
7.3.2	PIO mode access, memory write cycle . . . . .	<b>19</b>	8.4.2	Interrupt Enable register . . . . .	<b>54</b>
7.3.3	PIO mode access, register read cycle . . . . .	<b>19</b>	8.4.3	ISO IRQ Mask OR register . . . . .	<b>55</b>
7.3.4	PIO mode access, register write cycle . . . . .	<b>19</b>	8.4.4	INT IRQ Mask OR register . . . . .	<b>56</b>
7.3.5	DMA mode, read and write operations . . . . .	<b>19</b>	8.4.5	ATL IRQ Mask OR register . . . . .	<b>56</b>
7.4	Interrupts . . . . .	<b>21</b>	8.4.6	ISO IRQ Mask AND register . . . . .	<b>56</b>
7.5	Phase-Locked Loop (PLL) clock multiplier . . . . .	<b>23</b>	8.4.7	INT IRQ Mask AND register . . . . .	<b>56</b>
7.6	Power management . . . . .	<b>23</b>	8.4.8	ATL IRQ Mask AND register . . . . .	<b>57</b>
7.7	Overcurrent detection . . . . .	<b>25</b>	<b>9</b>	<b>Proprietary Transfer Descriptor (PTD)</b> . . . . .	<b>57</b>
7.8	Power supply . . . . .	<b>26</b>	9.1	High-speed bulk IN and OUT . . . . .	<b>60</b>
7.8.1	Hybrid mode . . . . .	<b>27</b>	9.2	High-speed isochronous IN and OUT . . . . .	<b>64</b>
7.9	Power-On Reset (POR) . . . . .	<b>27</b>	9.3	High-speed interrupt IN and OUT . . . . .	<b>68</b>
<b>8</b>	<b>Registers</b> . . . . .	<b>29</b>	9.4	Start and complete split for bulk . . . . .	<b>72</b>
8.1	EHCI capability registers . . . . .	<b>30</b>	9.5	Start and complete split for isochronous . . . . .	<b>76</b>
8.1.1	CAPLENGTH register . . . . .	<b>30</b>	9.6	Start and complete split for interrupt . . . . .	<b>80</b>
8.1.2	HCIVERSION register . . . . .	<b>30</b>	<b>10</b>	<b>Power consumption</b> . . . . .	<b>84</b>
8.1.3	HCSPARAMS register . . . . .	<b>30</b>	<b>11</b>	<b>Limiting values</b> . . . . .	<b>85</b>
8.1.4	HCCPARAMS register . . . . .	<b>31</b>	<b>12</b>	<b>Recommended operating conditions</b> . . . . .	<b>85</b>
8.2	EHCI operational registers . . . . .	<b>32</b>	<b>13</b>	<b>Static characteristics</b> . . . . .	<b>86</b>
8.2.1	USBCMD register . . . . .	<b>32</b>	<b>14</b>	<b>Dynamic characteristics</b> . . . . .	<b>88</b>
8.2.2	USBSTS register . . . . .	<b>33</b>	14.1	PIO timing . . . . .	<b>90</b>
8.2.3	USBINTR register . . . . .	<b>34</b>	14.1.1	Register or memory write . . . . .	<b>90</b>
8.2.4	FRINDEX register . . . . .	<b>34</b>	14.1.2	Register read . . . . .	<b>91</b>
8.2.5	CONFIGFLAG register . . . . .	<b>35</b>	14.1.3	Register access . . . . .	<b>91</b>
8.2.6	PORTSC1 register . . . . .	<b>36</b>	14.1.4	Memory read . . . . .	<b>92</b>
8.2.7	ISO PTD Done Map register . . . . .	<b>37</b>	14.2	DMA timing . . . . .	<b>93</b>
8.2.8	ISO PTD Skip Map register . . . . .	<b>37</b>	14.2.1	Single cycle: DMA read . . . . .	<b>93</b>
8.2.9	ISO PTD Last PTD register . . . . .	<b>38</b>	14.2.2	Single cycle: DMA write . . . . .	<b>94</b>
8.2.10	INT PTD Done Map register . . . . .	<b>38</b>	14.2.3	Multi-cycle: DMA read . . . . .	<b>95</b>
8.2.11	INT PTD Skip Map register . . . . .	<b>38</b>	14.2.4	Multi-cycle: DMA write . . . . .	<b>96</b>
8.2.12	INT PTD Last PTD register . . . . .	<b>39</b>	<b>15</b>	<b>Package outline</b> . . . . .	<b>97</b>
8.2.13	ATL PTD Done Map register . . . . .	<b>39</b>	<b>16</b>	<b>Abbreviations</b> . . . . .	<b>99</b>
8.2.14	ATL PTD Skip Map register . . . . .	<b>39</b>	<b>17</b>	<b>References</b> . . . . .	<b>100</b>
8.2.15	ATL PTD Last PTD register . . . . .	<b>40</b>	<b>18</b>	<b>Revision history</b> . . . . .	<b>101</b>
			<b>19</b>	<b>Tables</b> . . . . .	<b>102</b>
			<b>20</b>	<b>Figures</b> . . . . .	<b>104</b>
			<b>21</b>	<b>Contents</b> . . . . .	<b>105</b>

**Please Read Carefully:**

The contents of this document are subject to change without prior notice. ST-Ericsson makes no representation or warranty of any nature whatsoever (neither expressed nor implied) with respect to the matters addressed in this document, including but not limited to warranties of merchantability or fitness for a particular purpose, interpretability or interoperability or, against infringement of third party intellectual property rights, and in no event shall ST-Ericsson be liable to any party for any direct, indirect, incidental and or consequential damages and or loss whatsoever (including but not limited to monetary losses or loss of data), that might arise from the use of this document or the information in it.

ST-Ericsson and the ST-Ericsson logo are trademarks of the ST-Ericsson group of companies or used under a license from STMicroelectronics NV or Telefonaktiebolaget LM Ericsson.

All other names are the property of their respective owners.

© ST-Ericsson, 2009 - All rights reserved

Contact information at [www.stericsson.com](http://www.stericsson.com) under Contacts

**[www.stericsson.com](http://www.stericsson.com)**